

VLASE™ UV

PRODUCT REFERENCE GUIDE



UltraViolet DPSS Laser Marker

Datalogic S.r.l.

Via S. Vitalino, 13
40012 Calderara di Reno (BO)
Italy
Tel. +39 051 3147011
Fax +39 051 3147205

© 2021-2022 Datalogic S.p.A. and /or its affiliates

All rights reserved. Without limiting the rights under copyright, no part of this documentation may be reproduced, stored in or introduced into a retrieval system, or transmitted in any form or by any means, or for any purpose, without the express written permission of Datalogic S.p.A. and/or its affiliates.

Owners of Datalogic products are hereby granted a non-exclusive, revocable license to reproduce and transmit this documentation for the purchaser's own internal business purposes. Purchaser shall not remove or alter any proprietary notices, including copyright notices, contained in this documentation and shall ensure that all notices appear on any reproductions of the documentation.

Electronic versions of this document may be downloaded from the Datalogic website (www.datalogic.com). If you visit our website and would like to make comments or suggestions about this or other Datalogic publications, please let us know via the "Contact" page.

Disclaimer

Datalogic has taken reasonable measures to provide information in this manual that is complete and accurate, however, Datalogic shall not be liable for technical or editorial errors or omissions contained herein, nor for incidental or consequential damages resulting from the use of this material. Datalogic reserves the right to change any specification at any time without prior notice.

Trademarks

Datalogic and the Datalogic logo are registered trademarks of Datalogic S.p.A. in many countries, including the U.S.A. and the E.U.

Vlase™, Arex™, Eox™, Violino™ and Lighter™ Suite are trademarks of Datalogic S.p.A. and/or its affiliates. All other trademarks and brands are property of their respective owners.

This manual refers only to VLASE™ UV models running Windows 10 operating system (3039-1X43).

ORIGINAL INSTRUCTIONS (ref. 2006/42/EC)

TABLE OF CONTENTS

PREFACE	VII
About this Manual	vii
Manual Conventions	vii
Technical Support	vii
Support Through the Website	vii
Warranty	viii
CHAPTER 1. INTRODUCTION	1
About the Laser Marker	1
Model Description	2
Compliance	3
European Declaration of Conformity	3
UKCA Declaration of Conformity	3
FCC Compliance	3
EAC Compliance	3
Laser Standards	4
Overview	5
Main features:	5
Operation of a Laser Marker with Galvometric Scanning	6
Marking Software	6
Important Warnings	7
CHAPTER 2. INSTALLATION	8
Unpacking	8
Contents of the packaging	10
On moisture condensation	11
Note on moisture condensation	11
If moisture condensation occurs	11
How to avoid moisture condensation	11
Fixing and positioning	12
Control rack installation	13
Horizontal installation	13
Vertical installation	14
Control rack mounting screws length	14
Resonator installation	15
Resonator mounting screws length	15
Installation environment	16
Control Rack	16
Resonator	17
Fume / Dust extractor	18
CHAPTER 3. TECHNICAL SPECIFICATIONS	19
Technical Characteristics	19
Product Description	21
Resonator	21
Control Rack	22
Marking Area Specification	23
Connectors Specifications	25

Interlock	25
Control Rack back panel connector	25
Plug connector	26
Muting device	26
Interlock Out	27
Control Rack back panel connector	27
Plug Connector	28
X1 - Command Box (laser control)	29
Control rack back panel connector	29
Muting Device	31
X2 - Axes (I/O Control)	32
Control rack back panel connector	32
RS232	34
Control rack back panel connector	34
Encoder	35
Control rack back panel connector	35
Photocell	35
Control rack back panel connector	35
Input/Output specifications	36
Digital Input	36
Digital Output	36
Laser Marker State	37
Normal Operation States	37
Error States	37
Warning State	37
Control the Laser Marker States	38
Key and Enable Selector mode	38
Command Box mode	38
Timing Diagrams	39
Turning On sequence	39
Marking control signals behavior	39
MARVIS™ I/O signals behavior	40
Axes I/O signals behavior	40
Lighter™ Suite marking software	41
CHAPTER 4. SET UP	43
Connections	43
Fans installation	43
Connecting X1 - Command Box connector	44
Connecting Interlock connector	45
Connecting Interlock Out connector	46
Connecting the Optical Fiber to the control rack	46
Connecting the Optical Fiber on the resonator	49
Connecting Radiofrequency cable	51
Connecting MDR cable	52
Connecting Resonator cable	53
Connecting Fan cable	54
Connecting Power Supply cable	54
Connecting the Earth Ground	55
Connecting resonator power supply cable	55
Local Mode Control connections	56
Remote Mode Control connection	57
F-Theta scan lens protection cap removal	58
CHAPTER 5. USE AND OPERATION	59
Turning on sequence	60
Preliminary operation	60
Sequence using Key and Enable Selectors	61
Sequence Using X1 - Command Box	64

CHAPTER 6. CUSTOMIZE THE LASER MARKER SOFTWARE	66
System Protection	66
System Protection Tool	66
How to use the System Protection tool	67
Change o.s. language and keyboard layout	70
Change the LAN configuration and IP address	73
Change the video setting	76
Remote desktop connection	78
CHAPTER 7. ACCESSORIES	79
Control Box	79
Remote Start Foot Switch	80
I/O interface	80
MARVIS™ Add-on	81
DB25-to-Free Leads Cable	82
Fume Extractor	82
CHAPTER 8. TECHNICAL SUPPORT	83
Seals	83
Maintenance	84
F-Theta scan lens cleaning procedure	84
Air filter cleaning procedure	85
Troubleshooting	86
List of warning and error states	86
List of problems related to laser marker states	87
List of most common problems	87
Remote Assistance	90
APPENDIX A. LABELS	91
Labels	91
Positioning of external labels	93
Positioning of labels on the control rack:	93
Positioning of labels on the resonator:	94
APPENDIX B. SAFETY CONSIDERATION ACCORDING TO EN ISO 13489-1:2008	95
Performance level (PL)	95
Application example	96
Example automatic production line	96
Vlase™ safety logic details for automatic production line	98
Safety functions of Vlase™	99
APPENDIX C. LASER SAFETY	100
Laser radiation	100
Absorption of laser radiation	102
Classification and danger level	103
Degree of risk with radiation viewing conditions	103
Direct viewing of the laser beam	103
Viewing of a laser reflected beam	104
Viewing of direct laser beam from a fiber output	104
Viewing of scattered laser beam	104
N.O.H.D. determination and O.D. of protection goggles	105
EN207 and EN208	106
Eyes and skin risks	107
General safety regulations	107
Other risks	107
APPENDIX D. USING MARKING SOFTWARE	108
How to create and edit graphics layout	108
How to test and mark layout	110
How to use X1-Command Box signals to mark layout	112

Thermalization and suppression of giant pulses	114
APPENDIX E. MARKING SOFTWARE UPGRADE	116
How to update the marking software	116
APPENDIX F. RECOVER THE LASER MARKER	122
Overview	122
How to recover the laser marker	122
Preliminary Operation	123
Recover the system	124
APPENDIX G. MECHANICAL DRAWINGS	132
Control Rack	133
Resonator	134

PREFACE

ABOUT THIS MANUAL

This User Manual (UM) is provided for users seeking advanced technical information, including connection, programming, maintenance and specifications. The Quick Reference Guide (QRG) and other publications associated with this product can be downloaded free of charge from the website listed on the back cover of this manual.

Manual Conventions

The symbols listed below are used in this manual to notify the reader of key issues or procedures that must be observed when using the laser marker:



NOTE: Notes contain information necessary for properly diagnosing, repairing and operating the laser marker.



CAUTION: This symbol advises you of actions that could damage equipment or property.



WARNING: This symbol advises you of actions that could result in harm or injury to the person performing the task.

TECHNICAL SUPPORT

Support Through the Website

Datalogic provides several services as well as technical support through its website. Log on to (www.datalogic.com).

For quick access, from the home page click on the search icon , and type in the name of the product you're looking for. This allows you access to download Data Sheets, Manuals, Software & Utilities, and Drawings.

Hover over the Support & Service menu for access to Services and Technical Support.

WARRANTY

Datalogic warrants that the Products shall be free from defects in materials and workmanship under normal and proper use during the Warranty Period. Products are sold on the basis of specifications applicable at the time of manufacture and Datalogic has no obligation to modify or update Products once sold. The Warranty Period shall be **two years** from the date of shipment by Datalogic, unless otherwise agreed in an applicable writing by Datalogic.

Datalogic will not be liable under the warranty if the Product has been exposed or subjected to any: (1) maintenance, repair, installation, handling, packaging, transportation, storage, operation or use that is improper or otherwise not in compliance with Datalogic's instruction; (2) Product alteration, modification or repair by anyone other than Datalogic or those specifically authorized by Datalogic; (3) accident, contamination, foreign object damage, abuse, neglect or negligence after shipment to Buyer; (4) damage caused by failure of a Datalogic-supplied product not under warranty or by any hardware or software not supplied by Datalogic; (5) any device on which the warranty void seal has been altered, tampered with, or is missing; (6) any defect or damage caused by natural or man-made disaster such as but not limited to fire, water damage, floods, other natural disasters, vandalism or abusive events that would cause internal and external component damage or destruction of the whole unit, consumable items; (7) use of counterfeit or replacement parts that are neither manufactured nor approved by Datalogic for use in Datalogic-manufactured Products; (8) any damage or malfunctioning caused by non-restoring action as for example firmware or software upgrades, software or hardware reconfigurations etc.; (9) loss of data; (10) any consumable or equivalent (e.g. cables, power supply, batteries, etc.); or (11) any device on which the serial number is missing or not recognizable.

THE DATALOGIC WARRANTIES ARE EXCLUSIVE AND IN LIEU OF ALL OTHER WARRANTIES, WHETHER WRITTEN, EXPRESS, IMPLIED, STATUTORY OR OTHERWISE, INCLUDING, BUT NOT LIMITED TO, THE IMPLIED WARRANTIES OF MERCHANTABILITY AND FITNESS FOR PARTICULAR PURPOSE. DATALOGIC SHALL NOT BE LIABLE FOR ANY DAMAGES SUSTAINED BY BUYER ARISING FROM DELAYS IN THE REPLACEMENT OR REPAIR OF PRODUCTS UNDER THE ABOVE. THE REMEDY SET FORTH IN THE WARRANTY STATEMENT IS THE BUYER'S SOLE AND EXCLUSIVE REMEDY FOR WARRANTY CLAIMS. NO EXTENSION OF THIS WARRANTY WILL BE BINDING UPON DATALOGIC UNLESS SET FORTH IN WRITING AND SIGNED BY DATALOGIC'S AUTHORIZED REPRESENTATIVE. DATALOGIC'S LIABILITY FOR DAMAGES ON ACCOUNT OF A CLAIMED DEFECT IN ANY PRODUCT DELIVERED BY DATALOGIC SHALL IN NO EVENT EXCEED THE PURCHASE PRICE OF THE PRODUCT ON WHICH THE CLAIM IS BASED. DATALOGIC SHALL NOT BE LIABLE FOR DAMAGES RELATING TO ANY INSTRUMENT, EQUIPMENT, OR APPARATUS WITH WHICH THE PRODUCT SOLD UNDER THIS AGREEMENT IS USED. Further details on warranty coverage, rights and conditions are addressed under and regulated by the Terms and Conditions of Sales of Datalogic available at https://www.datalogic.com/terms_conditions_sales.

CHAPTER 1

INTRODUCTION

ABOUT THE LASER MARKER

Information included in this manual is intended for a qualified installer able to integrate the laser marker into a system, complying with all the protection features required by international rules and local legislations. Refer to the following sections for further information.

This manual refers to VLASE™ UV laser markers, that is a Class 4 Laser Product.

In addition to being professionally trained in their role, personnel assigned to work with laser marker must be informed and made acquainted with the risks inherent to invisible and visible laser radiation. The operator is required to carefully read the section of the manual concerning safety instructions as well as the sections related to matters falling under her/his responsibility.



CAUTION: Datalogic shall not be held responsible for any non-conforming use of the laser marker of its manufacture.



NOTE: BEFORE INSTALLING AND USING THE LASER MARKER, CAREFULLY READ THIS MANUAL.

MODEL DESCRIPTION

Vlase™ UV laser markers are described by their model number which indicates the characteristics listed in the diagram below. Not all combinations are available. For a complete list of combinations see the Models tab on the Product page of the website.



VLASE 3039-1X43

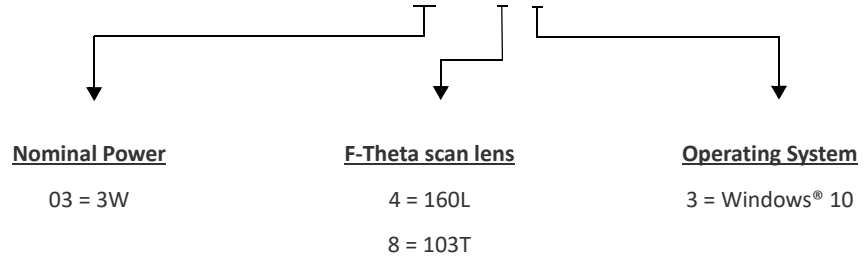

COMPLIANCE

European Declaration of Conformity

Hereby, Datalogic S.r.l. declares that the full text of the European Declaration of Conformity is available at: www.datalogic.com. Select the link from the downloads section of the product page.

UKCA Declaration of Conformity

Hereby, Datalogic S.r.l. declares that the full text of the UKCA Declaration of Conformity is available at: www.datalogic.com. Select the link from the downloads section of the product page.

FCC Compliance

Modifications or changes to this equipment without the expressed written approval of Datalogic could void the permission to use the equipment.

This laser marker complies with PART 15 of the FCC Rules. Operation is subject to the following two conditions: (1) this laser marker may not cause harmful interference, and (2) this laser marker must accept any interference received, including interference which may cause undesired operation.

This laser marker has been tested and found to comply with the limits for a Class A digital device, pursuant to part 15 of the FCC Rules. These limits are designed to provide reasonable protection against harmful interference when the equipment is operated in a commercial environment. This laser marker generates, uses, and can radiate radio frequency energy and, if not installed and used in accordance with the instruction manual, may cause harmful interference to radio communications. Operation of this laser marker in a residential area is likely to cause harmful interference in which case the user will be required to correct the interference at his/her own expense.

EAC Compliance

Customs Union: this laser marker complies with CU Conformity certification; this allows the Product to bear the Eurasian Mark of conformity.

LASER STANDARDS

This laser marker is classified as Class 4 Laser Product according to the following:

EU: EN60825-1

USA: 21 CFR 1040.10

China: GB7247-1

Datalogic, as manufacturer of laser products, provides a laser marker which is NOT intended for immediate use, but it must be connected, by others, to other devices which have the final aim of creating a laser processing system.

The final system manufacturer MUST ensure the safety of the laser processing machine according to its standards including the risk-analysis, implementation of safety measures, certification and testing of safety measures and the production of adequate information for use of the machine.

Datalogic is available for providing to the customers all the information in its possession to help in complying with applicable standards.



WARNING: Use of controls or adjustments or performance of procedures other than those specified herein may result in hazardous radiation exposure.

OVERVIEW

The Vlase™ laser marker features a control unit whose size is compatible with the standard 19" 2,5U in varnished steel, and a resonator whose compact dimensions make it easy to integrate into a system that comprises safety devices required by applicable regulations, the management of marking signals and the customer's complementary modules, if any.

All laser marker connections are found on the rear of the rack: power supply, safety, electrical signals, communication ports, patch cord to the scanner head, while the front features key and enable command devices, status LED in addition to a USB connector for the communication with the internal embedded controller.

Vlase™ belongs to the family of DPSS (Diode Pump Solid State) laser sources in the "end pumped" and "Q-Switched" configuration.

The mechanical and electrical characteristics satisfy standardization and connectivity needs of the industrial field, such as the new 19" rack and different solutions for laser marker control.

The new laser marker control platform allows for an easy integration in industrial environments and complies with the standard of the other Datalogic laser markers, with the same philosophy implemented in Arex™.

Based on the optical layout of the Datalogic Violino™ laser source, the Vlase™ family guarantees significant improvements in terms of performance thanks to the new laser diode current and temperature controllers, developed by the Datalogic laboratories, which shorten warm-up time and improve the stability of emitted laser power. The operating temperature range has been extended to 5° - 40°C for its use in industrial environments.

Main features:

- 100 to 240 V AC @ 50-60Hz Power Supply
- Operating Temperature Range extended to 40°C
- Fully integrated marking and system control
- Integrated PC embedded and marking software for stand-alone operation
- Ease of integration in industrial environments and maximum control compatibility with other marking platforms (Arex™/Eox™/UniQ™)
- Integrated photocell and encoder connectors for Marking On Fly (MOF) applications
- Unattended control of the system by LAN network or serial communication (RS232 protocol)
- Stable Marking process and high a beam quality ($M^2 < 1.3$)
- Compact Design: 19" 2,5U rack
- High peak power and short pulse duration (<10ns)
- Available cable lengths: 3m standard, other lengths available on request
- Simplified access to Laser Diode Module for fiber installation and Laser Diode Module maintenance
- Dedicated software tool for laser parameter setting and diagnostics

Operation of a Laser Marker with Galvometric Scanning

During the marking the laser generates an invisible, high-energy infrared beam.

In order to obtain a more accurate focus, the laser beam is first enlarged using an optical expansion system and then deflected by a scanning system consisting of two mirrors mounted on galvanometric motors.

These mirrors deflect the beam in a controlled path along the X and Y axes; processing of the product surface occurs by coordinating the movement of the two mirrors and the turning on/off of the laser beam.

The deflected laser beam is focused by an F-Theta scan lens on the surface of the product.

Generally speaking, the marking is carried out within the focus plane of the F-Theta scan lens.

Marking Software

The Lighter™ marking software is preinstalled on the product.



NOTE: Consult Lighter™ software user's manual for a proper use of the same.



NOTE: If necessary, consult See “How to update the marking software” on page 116., to upgrade the preinstalled software.

IMPORTANT WARNINGS

Access to the internal parts of the laser marker is allowed only to authorized personnel, duly qualified and trained with regards to risks of optical and electrical nature.

Datalogic declines any and all responsibility for work carried out on active parts by untrained or unauthorized personnel.



CAUTION: It is forbidden to change the intended use for which the product was designed and developed.

Datalogic declines any and all responsibility for improper use of its laser product.



CAUTION: The integration and use of this laser marker is customer responsibility.



CAUTION: Never expose reflecting surfaces to laser radiation! The reflected laser beam may cause damage to laser marker.



CAUTION: Laser marking interacts with materials through, for example, a thermal carbonization process which may lead to the emission of fumes, dust and vapors.

Adequate fume/dust extractor and treatment must be provided by customer!



WARNING: Marking PVC (or other plastic material) can cause the release of chlorine gas which can be harmful to the laser operator and to the laser marker itself. Always use adequate fume extractor during PVC and plastic marking.



CAUTION: It is the responsibility of the customer to install the laser marker in proper safety condition!

CHAPTER 2

INSTALLATION

UNPACKING



CAUTION: The Vlase™ UV laser marker is a delicate optical device, that can be damaged by shock and vibrations.

Before installing or operating the laser marker, you should:

- Inspect the shipping container for damage
- Inspect the laser marker for signs of damage
- Confirm that the shipping box contains all items on the shipping inventory list including any accessories

When unpacking the laser marker from the shipping box you should:

- Remove the accessories and documentations
- Carefully remove the laser marker from the packaging using both hands.

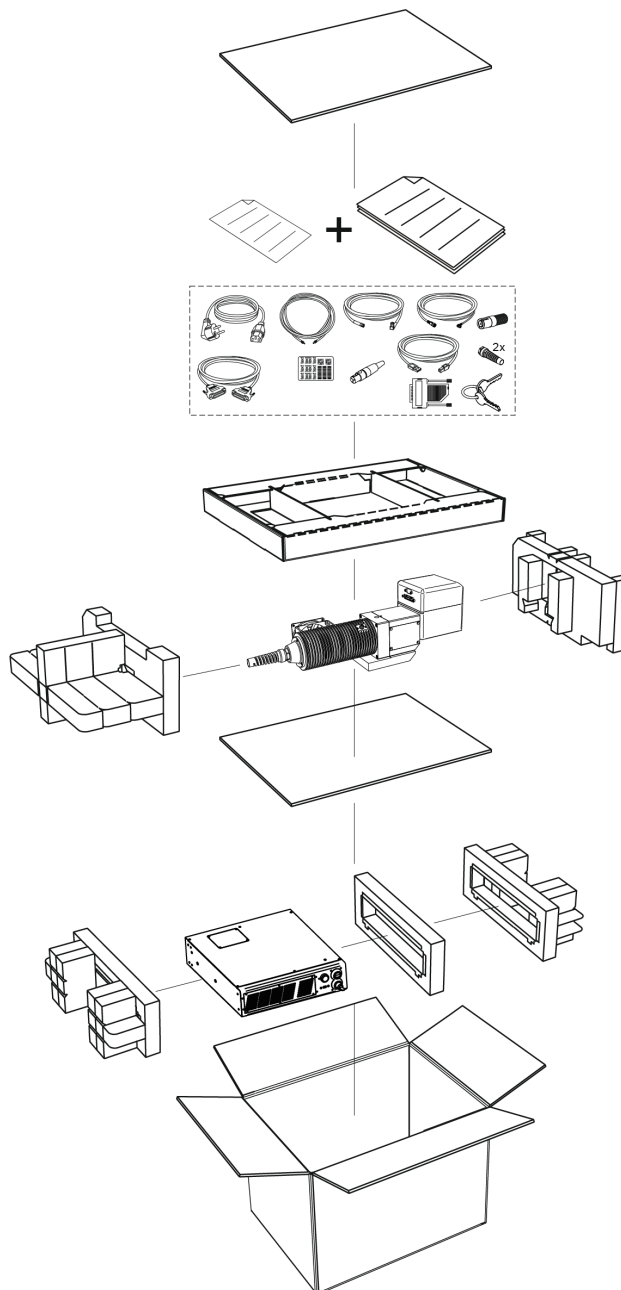

Figure 1: Unpacking

Keep all packing materials until the laser has been inspected for completeness and damage. If something is missing or defective, call Datalogic (see "[Technical Support](#)" on page [vii](#) for contact details).

Be sure to use the original packaging material for the transportation of this laser marker, otherwise transportation could cause malfunctions or damage. Keep the original packaging materials for future use. Be careful to ship the laser marker following the recommendations present in the packaging labels.

CONTENTS OF THE PACKAGING

 <p>Control Rack</p>	 <p>Resonator</p>	 <p>6x Power Supply cables</p>	
 <p>RF Cable</p>	 <p>Resonator Cable</p>	 <p>Optical fiber cable</p>	 <p>USB cable</p>
 <p>MDR Cable</p>	 <p>4x M4x8 Rack Fixing Brackets</p>	 <p>Interlock cable</p>	
 <p>Command Box MUTING DEVICE</p>	 <p>Interlock MUTING DEVICE</p>	 <p>Interlock OUT</p>	
 <p>Selector keys</p>	 <p>EULA Windows 10</p>	 <p>2x Cable glands</p>	
 <p>Test report and sample test plate</p>	 <p>Quick Reference Guide</p>		

ON MOISTURE CONDENSATION

If the laser marker is brought directly from a cold to a warm location, moisture may condense inside or outside the laser product. This moisture condensation may cause a malfunction of the laser marker.

Note on moisture condensation

Moisture may condense when you bring the laser marker from a cold place into a warm place (or vice versa) and when you use the laser marker in a humid place.

If moisture condensation occurs

Turn off the laser marker and wait about 1 hour for the moisture to evaporate.

How to avoid moisture condensation

Before moving the laser marker from a cold place into a warm place, put it in a plastic bag and seal it tightly. Remove the bag when the air temperature inside the plastic bag has reached the ambient temperature (after about 1 hour).

FIXING AND POSITIONING



CAUTION: Fix the laser marker according to instructions shown in the figures.



CAUTION: It is mandatory to secure the laser marker before you start marking, since improper securing or positioning may cause serious damage.

Do not secure the laser marker in a way other than the one described in the figure.



CAUTION: Introduction of optical or mechanical surfaces, such as mechanical shutters or additional protective glass, between F-Theta scan lens output and marking surface may cause optical feedback into the laser marker.

Optical induced damage caused to laser marker by reflection from external surfaces is not covered by warranty.



NOTE: In order to prevent marking distortions, avoid vibrations and bumps during the marking process!



NOTE: It is recommended to install the resonator on a positioning Z-axis system for accurate mounting at focal distance!

CONTROL RACK INSTALLATION

Horizontal installation

The control rack must be positioned in a safe manner, following the recommendations below.

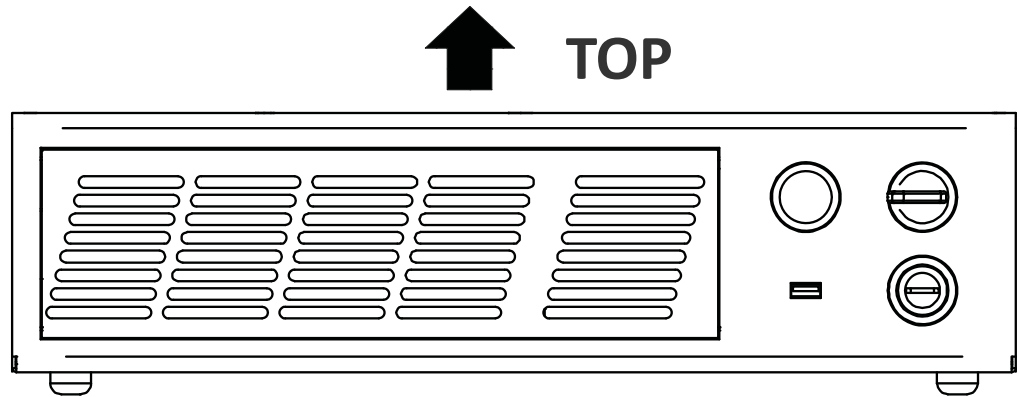

Figure 2: Control rack horizontal positioning

The control rack can be installed on a standard 19" rack cabinet using the fixing brackets supplied as a standard equipment.

The figure below shows the fixing points for installation in a rack cabinet.

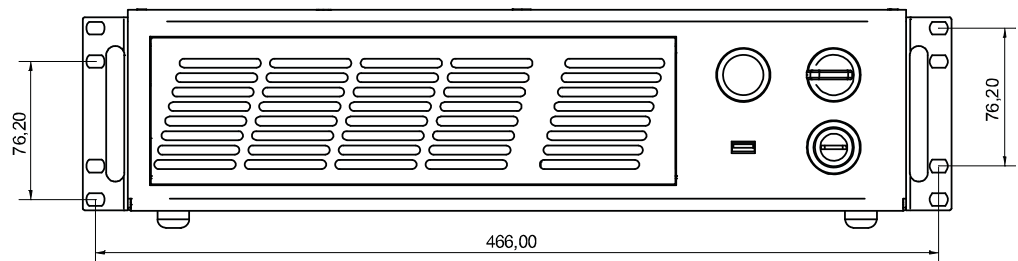

Figure 3: Control rack fixing bracket mounting configuration



NOTE: All dimensions are in millimeters.

Vertical installation

The control rack must be positioned in a safe manner, following the recommendations below.

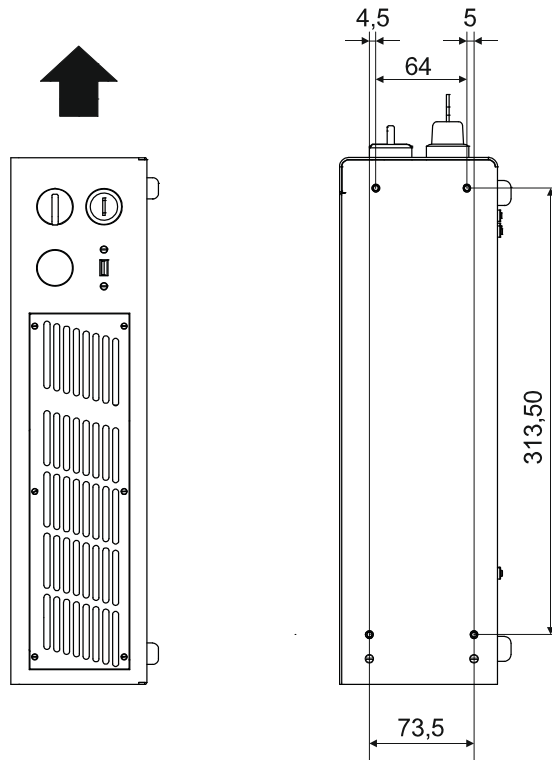

Figure 4: Control rack vertical positioning



NOTE: All dimensions are in millimeters.



CAUTION: The control rack **MUST** be fixed to a side wall using the appropriate fixing points placed on the side of the control rack.

Control rack mounting screws length

To determine the length of the mounting screws, consider the thickness of the mounting plate and the thickness of the washer.

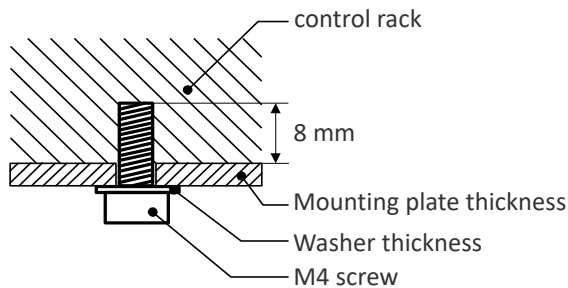

Figure 5: Length of mounting screws.



NOTE: Mounting holes depth is = 8mm. Tightening torque = 2 Nm.

RESONATOR INSTALLATION

The resonator can be installed in any orientation and must be fixed to a suitable base (not supplied by Datalogic) using the dedicated threaded holes.

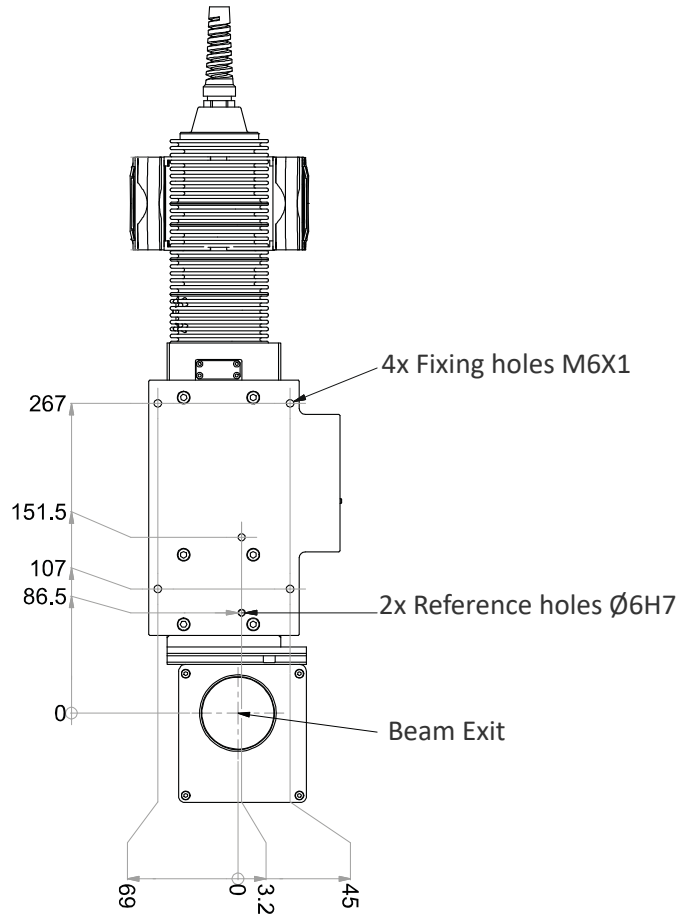

Figure 6: Resonator fixing points



NOTE: All dimensions are in millimeters.

Resonator mounting screws length

To determine the length of the mounting screws, consider the thickness of the mounting plate and the thickness of the washer.

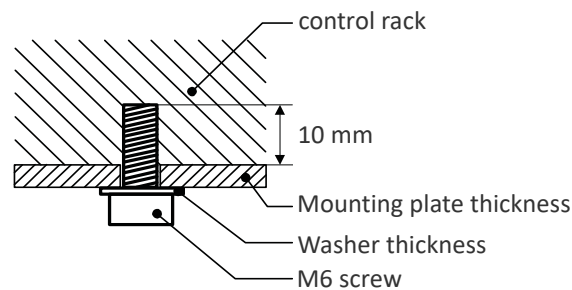

Figure 7: Length of mounting screws.



NOTE: Mounting holes depth is = 10mm. Tightening torque = 2 Nm.

INSTALLATION ENVIRONMENT

Control Rack

The control rack must be installed in a suitable environment in order to allow proper air flow and correct housing of the cables.

The control rack uses a forced air cooling system: an adequate air flow is necessary to guarantee its correct cooling. Install the control rack so that air flow is not obstructed. Moreover, do not install it near a heat source.



CAUTION: If not enough space is provided, the temperature inside the control rack could rise, causing temperature error.

Clean the air filter when it is dirty. If the air filter is dirty, insufficient air-flow might not ensure correct cooling and might stop the marking operation. Clean or replace the air filter periodically.

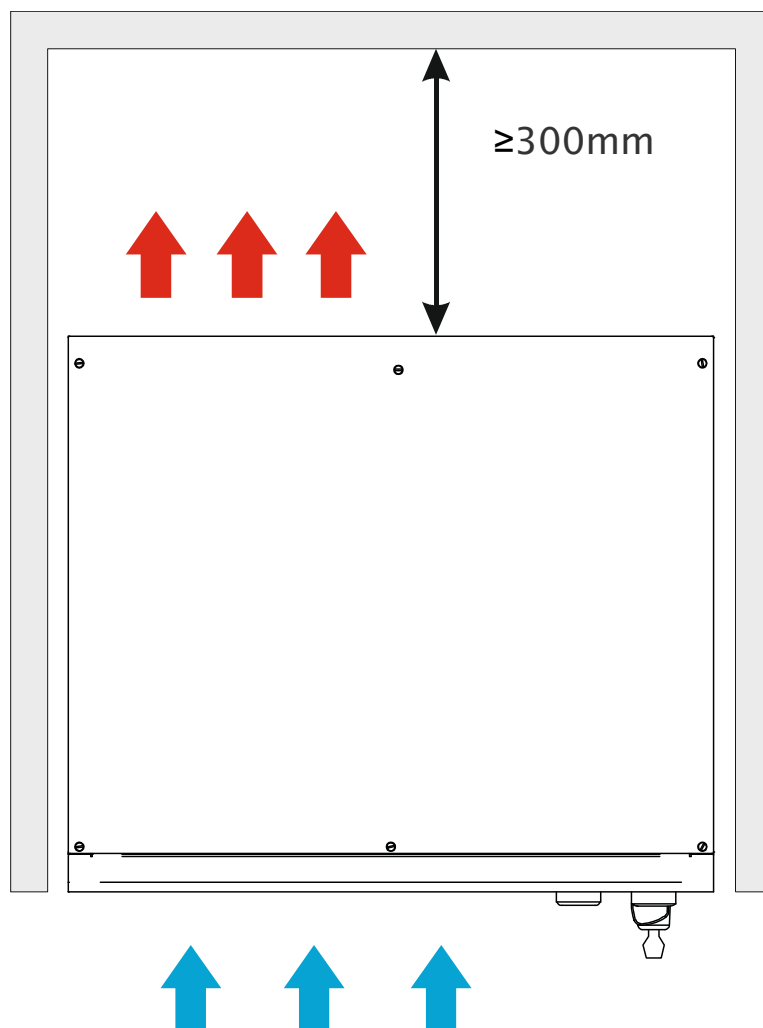

Figure 8: Control rack installation environment



CAUTION: DO NOT place heavy objects on top of the control rack!

Resonator

The resonator must be installed in a suitable environment in order to allow proper air flow and correct housing of the cables.

The resonator uses a forced air cooling system: an adequate air flow is necessary to guarantee its correct cooling. Install the resonator so that air flow is not obstructed. Moreover, do not install it near a heat source.



CAUTION: If not enough space is provided, the temperature inside the control rack could rise, causing temperature error.

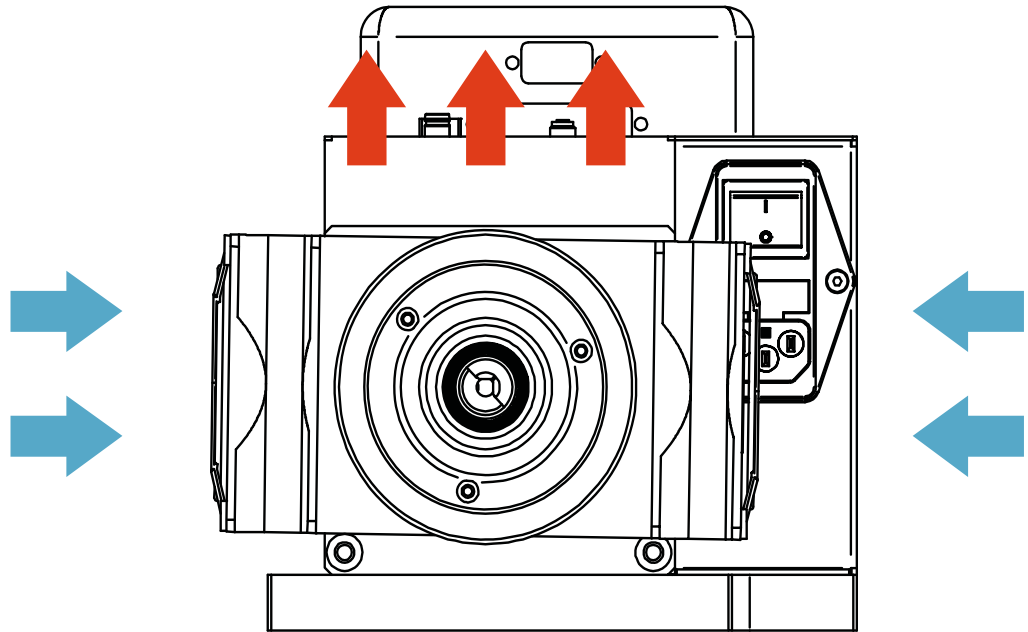

Figure 9: Resonator installation environment

FUME / DUST EXTRACTOR

During the marking process, dust and/or fume may be produced. It is important to use an adequate fume/dust extractor and/or air filtration (see "Fume Extractor" on page 82).



CAUTION: Marking PVC (or other plastic material) can cause the release of chlorine gas which can be harmful to the laser operator and to the laser marker itself. Always use adequate fume extractor during PVC and plastic marking.

CHAPTER 3

TECHNICAL SPECIFICATIONS

TECHNICAL CHARACTERISTICS

VLASE UV MODELS		3039-1X43
ELECTRICAL SPECIFICATIONS		
Input Voltage (main power supply)	V (AC)	100 to 240 @ 50-60 Hz
Max. Input Current (main power supply)	A	6
Max power	W	600
LASER SOURCE SPECIFICATIONS¹		
Laser Type		DPSSL (Diode Pumped Solid State Laser)
Nominal Power	W	3
Pulse Energy (max.)	mJ	0.10 (7 ns)
Peak Power (max.)	kW	14
Central Emission Wavelength	nm	355
Repetition Rate ²	kHz	20 to 80
Laser Aiming Beam		Class 2: 630-670 nm
ENVIRONMENTAL SPECIFICATIONS		
Operating Temperature	C (F)	5° to 40° (41° to 104°)
Storage Temperature	C (F)	-10° to 60° (14° to 140°)
Humidity	%	< 90 without condensation
Altitude	m	2000
Shock and Vibration		MIL 810E "CAT 1 Basic Transportation"
Package Drop Test	cm	60
Pollution Degree		2
Overvoltage Category		II

VLASE UV MODELS		3039-1X43
PHYSICAL SPECIFICATIONS		
Control Rack dimensions (HxWxD)	mm in	122x430x480 4.8x16.9x18.9
Control Rack Weight	Kg lbs	15 33.1
Control Rack Cooling		Forced Air Fans: L10@40°C = 60000 h
Resonator dimensions (HxWxD) ³	mm in	168x181x686 6.6x7.1x27
Resonator Weight ⁴	Kg lbs	11 24.2
Resonator Cooling		Forced Air Fans: L10@40°C = 70000 h
Noise	dB (A)	<70 at 1 meter
Optical fiber minimum Bending Radius	mm in	200 (fixed installation) 7.87 (fixed installation)
Cables length	m	3
OTHER SPECIFICATIONS		
Marking speed ⁵	mm/s	Up to 3000
Char Marking Speed ⁶	char/s	Up to 340
MOF (marking on fly)		YES (constant speed or encoder)
Line speed ⁷ - Productivity	m/min pcs/s	Up to 75 3
Marking Control and Software		EMC (Embedded Marking Control) and Lighter™ Suite
Communication		RS232, Ethernet (TCP/IP 10, 100 Mbit), EtherNet/IP ProfiNet I/O, TcpServer Protocol, Digital I/O

1. Specification @ 25°C
2. Without power derating
3. Varies by model
4. Without F-Theta scan lens
5. May vary: measured with $f = 160L$ mm
6. Char in Roman-s font, 1mm height, Level100% $f=30Hz$, F-Theta scan lens 160L on TESA label
7. Single line string, Roman-s font

PRODUCT DESCRIPTION

Resonator

A description of the main parts of the resonator unit is provided here below:

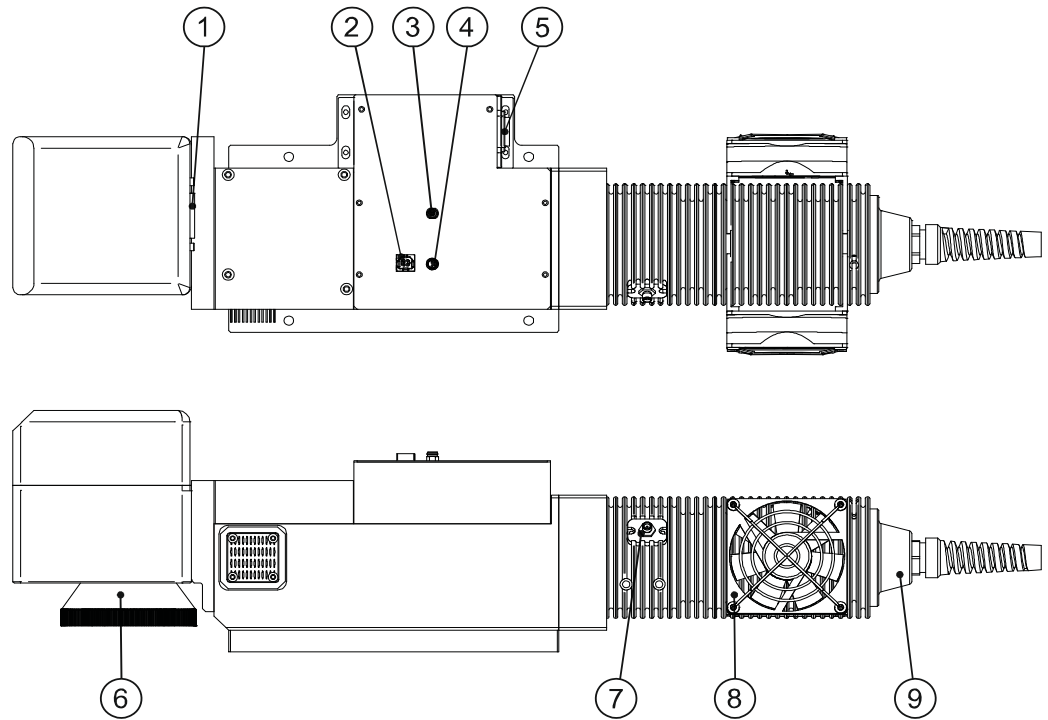

Figure 10: Resonator overview (bottom and side views)

1. MDR signals connector
2. USB type B plug
3. Fans connector
4. Resonator connector
5. Resonator power supply connector
6. F-Theta Scan Lens
7. RF connector
8. Cooling fan
9. Optic fiber inlet

CONTROL RACK

A description of the main parts of the control rack unit is provided here below:

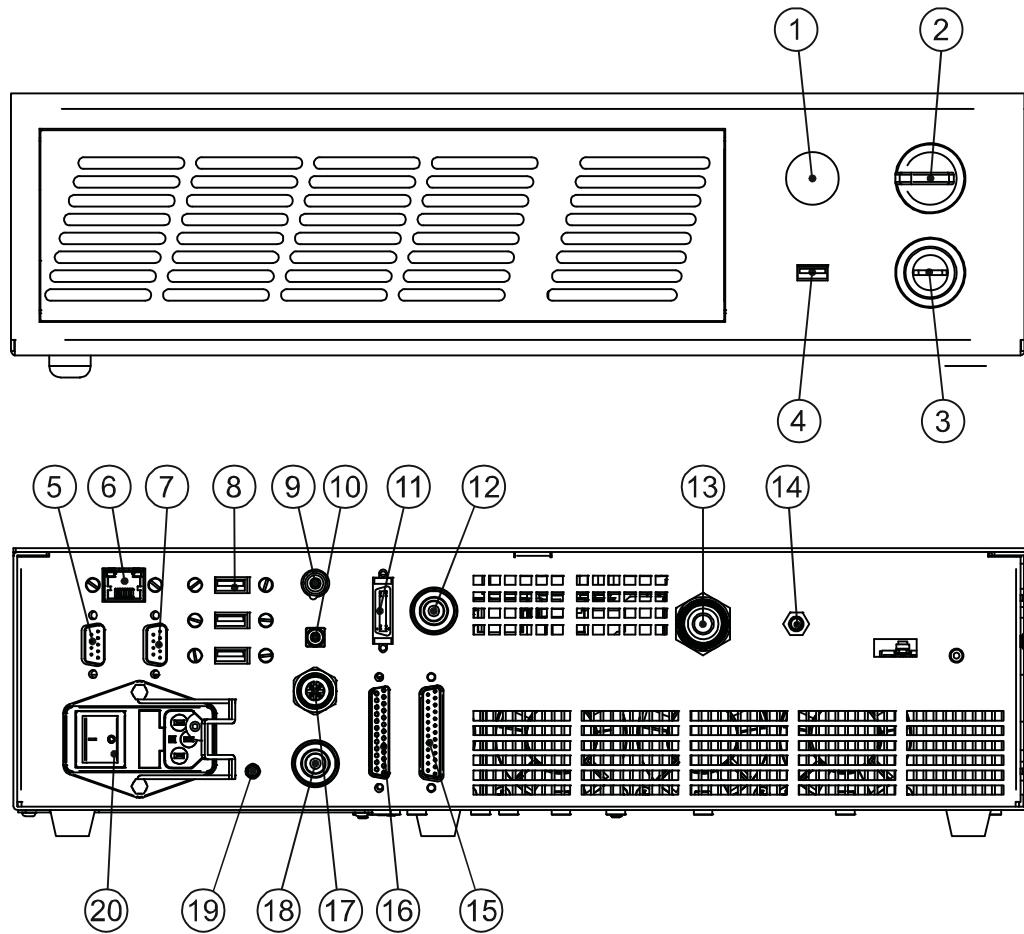

Figure 11: Control Rack overview (front and back views)

1. Status LED
2. Enable selector
3. Key selector
4. USB port
5. VGA port
6. LAN port
7. RS232 port
8. 3x USB ports
9. Interlock connector
10. Interlock OUT connector
11. MDR signal connector
12. Resonator connector
13. Optic fiber outlet
14. RF connector
15. X1 - Command Box connector
16. X2 - Axes connector (I/O control)
17. Photocell connector
18. Encoder connector
19. Earth ground
20. Main power supply connector

MARKING AREA SPECIFICATION

Datalogic provides a wide range of laser marker models with different F-Theta scan lenses configurations.

These configurations are provided to best match customer needs regarding marking field size, working distance and power density.



NOTE: Contact Datalogic if other configurations are necessary.



NOTE: Definition of Marking Area: square marking field measured on black anodized aluminum plate.



CAUTION: This product was designed to use only certain configurations of F-Theta scan lens and marking field. If your needs are not satisfied by the currently available F-Theta scan lens configurations please contact Datalogic for a solution. The use of other F-Theta scan lenses or operation outside the specified marking field for a certain F-Theta scan lens configuration can lead to damage of the F-Theta scan lens, resonator or laser source. Such damage is not covered by warranty!



CAUTION: For each F-Theta scan lens configuration Datalogic provides a specific adapter. This adapter ensures that residual back reflections caused by the F-Theta scan lens do not damage the scanning head optics. The removal of such adapter or its incorrect use (for example incomplete threading, use of another F-Theta scan lens adapter, etc.) can lead to damage of the F-Theta scan lens, resonator or laser source. Such damage is not covered by warranty!

The table below lists the standard F-Theta scan lenses currently available:

F-Theta Scan Lens diameter M85			
F-THETA SCAN LENS		$f = 103T$ Telecentric	$f = 160L$
Working Distance (WD)	mm	135 ± 3	197 ± 3
Fixing Distance (FD)	mm	159 ± 4	187 ± 4
Marking Area (MA)	mm ²	60 x 60	110 x 110



NOTE: Working Distance is defined as the distance between the center of the marking area (defined in the focal plane) and the closest mechanical edge of the F-Theta scan lens. Refer to the following figure.



NOTE: Fixing Distance is defined as the distance between the base of the resonator and the marking area. Refer to the following figure.

WD: Working Distance

FD: Fixing Distance

MA: Marking Area

AB: Aiming Beam

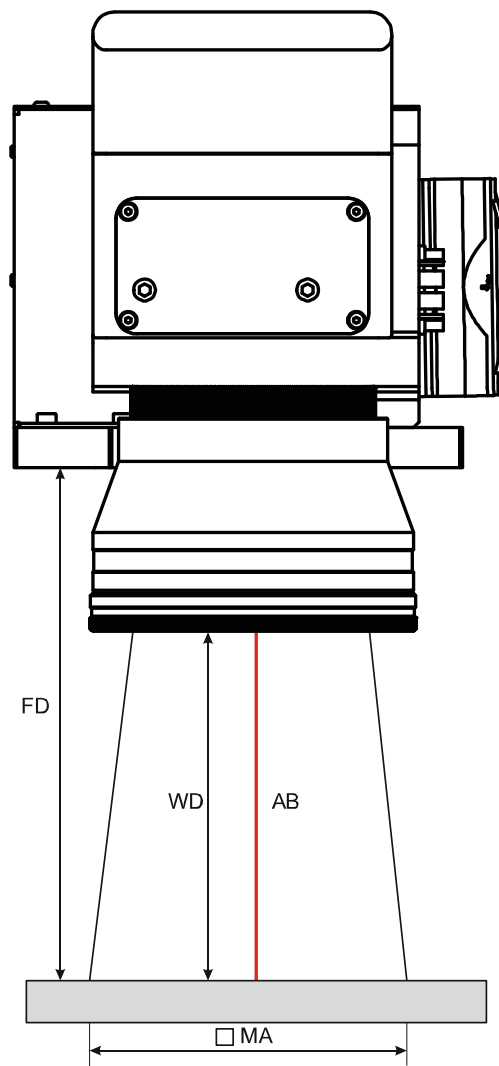

Figure 12: Marking Area

CONNECTORS SPECIFICATIONS

Interlock

Disables the Class4 laser source inside the laser marker. Interlock internal circuit is designed to comply with the single fault condition.

Control Rack back panel connector

Type SWITCHCRAFT TB Series male Tini Q-G (Mini XLR) panel mount connector, 4 pins.

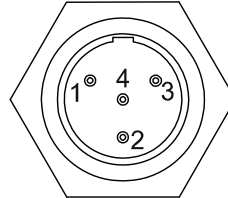

Figure 13: Interlock connector, male panel plug (front view)

PIN	SIGNAL	TYPE	DESCRIPTION
1	VCC_INT_IN_A	OUTPUT	24V DC reference for INTERLOCK_A signal
2	INTERLOCK_A	INPUT	INTERLOCK IN signal A
3	GND_INT_IN_B	GND	Ground reference for INTERLOCK_B signal
4	INTERLOCK_B	INPUT	INTERLOCK IN signal B

Table 1: Interlock connector pinout

Electric Diagram

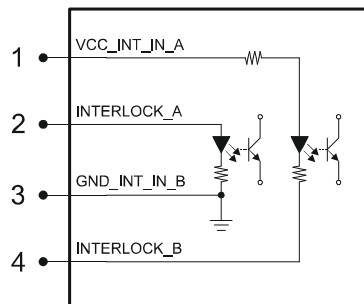

Figure 14: Interlock connector electric diagram

PIN1-PIN2	PIN3-PIN4	MARKING FUNCTIONALITY	CONDITION
CONTACT OPEN	CONTACT OPEN	NOT POSSIBLE	SAFE
CONTACT CLOSED	CONTACT OPEN	NOT POSSIBLE	DANGEROUS
CONTACT OPEN	CONTACT CLOSED	NOT POSSIBLE	DANGEROUS
CONTACT CLOSED	CONTACT CLOSED	NOT POSSIBLE	DANGEROUS

Table 2: Interlock connector conditions



CAUTION: In order to **NOT DAMAGE** the interlock circuitry, we recommend using “dry circuit” (zero voltage) switches or relay circuitry.

Plug connector

Connector type SWITCHCRAFT TA Series Tini Q-G (Mini XLR) female cable mount connector, 4 pins.

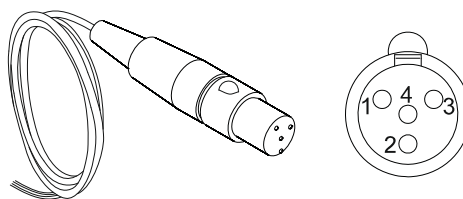

Figure 15: Female cable mount connector cod. TY4F (solder view)



CAUTION: To restore the laser marker it is necessary to repeat the "Turning on sequence" on page 60 without shutting down the system.

Muting device

Connector type SWITCHCRAFT TA Series Tini Q-G (Mini XLR) female plug connector, 4 pins.

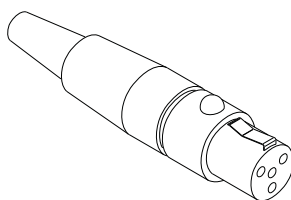

Figure 16: Interlock Muting Device provided



CAUTION: Do not use the Interlock Muting Device for external devices, since this will result in loss of the safety function of the machine to which this product is installed.

Do not use the Interlock Muting Device except for maintenance of this product.



CAUTION: It is the customer's responsibility to provide a correct integration of the safety signals according to applicable regulations.

Internal Electric Diagram

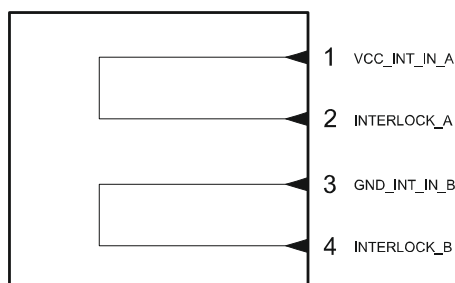

Figure 17: Interlock Muting Device electric diagram

Interlock Out

The Interlock Out allows monitoring of the interlock connector operation.

Control Rack back panel connector

Panel socket BINDER, 4 pins female, 719 series.

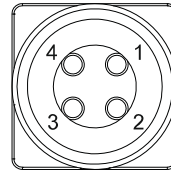

Figure 18: Interlock Out connector, female panel socket (front view)

PIN	SIGNAL	TYPE	DESCRIPTION
1	INT_OUT_A_COLLECTOR	COLLECTOR	Interlock Out signal A (INT_OUT_A)
2	INT_OUT_A_EMITTER	EMITTER	
3	INT_OUT_B_COLLECTOR	COLLECTOR	Interlock Out signal B (INT_OUT_B)
4	INT_OUT_B_EMITTER	EMITTER	

Table 3: Interlock Out connector pinout

Electric Diagram

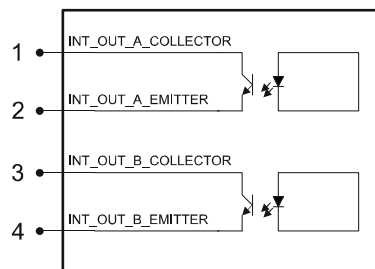

Figure 19: Interlock Out connector electric diagram

INT_OUT_A	INT_OUT_B	CONDITION
CLOSED	CLOSED	SAFE
CLOSED	OPEN	DANGEROUS
OPEN	CLOSED	DANGEROUS
OPEN	OPEN	DANGEROUS

Table 4: Interlock Out connector conditions

TECHNICAL CHARACTERISTICS	
Type	NPN BJT Transistor
V _{max}	300 V
I _{max}	60 mA
V _{saturation}	< 1.5 V
Leakage current	< 400 nA



NOTE: The response time is 10 ms from the output's switching.

Plug Connector

Binder male cable mount connectors, 719 series, 4 pins.

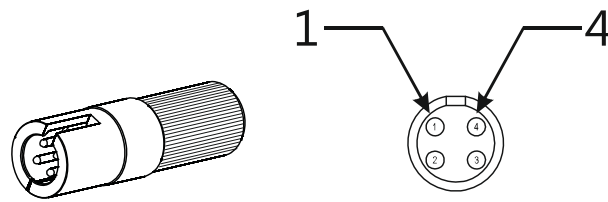

Figure 20: Male cable mount connector cod. 09-9767-00-04 (front view)

X1 - Command Box (laser control)

Control rack back panel connector

Panel socket Sub-D, 25 pins, female.

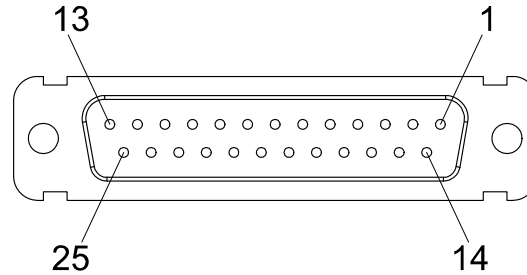

Figure 21: X1 - Command Box connector, female panel socket (front view)

PIN	SIGNAL	TYPE***	DESCRIPTION
X1.1	12V_ENABLE_B	Output Power Supply	12V DC power supply available for EXT_ENABLE_B (max 250mA)
X1.2	EXT_ENABLE_B	Digital Input	Secondary external ENABLE signal: - HIGH level: contact closed - LOW level or disconnected: contact opened
X1.3	RESERVED	Digital Output	DO NOT CONNECT
X1.4	EXT_12V	Output Power Supply	Auxiliary 12V DC power supply available for drive input logical HIGH (max 250mA)
X1.5	EXT_12V	Output Power Supply	Auxiliary 12V DC power supply available for drive input logical HIGH (max 250mA)
X1.6	EXT_12V	Output Power Supply	Auxiliary 12V DC power supply available for drive input logical HIGH (max 250mA)
X1.7	12V_ENABLE_A	Output Power Supply	12V DC power supply available for EXT_ENABLE_A (max 250mA)
X1.8	EXT_ENABLE_A	Digital Input	Primary external ENABLE signal: - HIGH level: contact closed; - LOW level or disconnected: contact opened
X1.9	BUSY*	Digital Output	This signal is used to know if the current spooler is executing (marking in progress): - ON during marking process
X1.10	CONNECTOR PRESENCE	Digital Input	This signal is used to check the presence of the Command Box connector: - HIGH level: normal operation; - LOW level or disconnected
X1.11	START_MARKING*	Digital Input	This signal is used to start to the marking process when a document or a sequence is running in AUTO MODE** or WORK MODE**: - HIGH level pulsed signal start the marking process
X1.12	EXT_KEY	Digital Input	External KEY signal: - HIGH level: contact closed; - LOW level or disconnected: contact opened
X1.13	STOP_MARKING*	Digital Input	This signal is used to stop the marking process: - HIGH level pulsed signal stop the marking process

PIN	SIGNAL	TYPE***	DESCRIPTION
X1.14	RESERVED	Digital Input	DO NOT CONNECT
X1.15	RESERVED	Digital Input	DO NOT CONNECT
X1.16	RESERVED	Digital Input	DO NOT CONNECT
X1.17	END	Digital Output	This signal is used to know if the marking process is finished: - ON at the end of marking process
X1.18	POWER_ON	Digital Output	This signal is used to know if the system is already warmed up: - ON when the laser is in STAND_BY or READY state
X1.19	GND	Ground	Ground reference
X1.20	SYSTEM_ALARM	Digital Output	This signal is used to know if the system is in booting up state or in error state: - ON during BOOTING UP - ON in case of system error
X1.21	GND	Ground	Ground reference
X1.22	ENABLE_OUT	Digital Output	This signal is used to know if the system is ready to emit laser radiation: - ON when the system is in READY state
X1.23	SW_READY*	Digital Output	This signal is used to know if a document, sequence or script is loaded and ready to be executed: - ON when a document or a sequence is running in AUTO MODE** or WORK MODE** (SW_READY COMPATIBILITY** = true) - ON when a document or a sequence is running in AUTO MODE** and laser in READY state (SW_READY COMPATIBILITY** = false) - ON when a script is running in AUTO MODE** and "IoPort.setReady (true)" function is used
X1.24	GND	Ground	Ground reference
X1.25	GND	Ground	Ground reference

Table 5: X1 - Command Box connector pinout

* refers to Lighter user's manual "Setting I/O parameters" paragraph to set the signal properties

** refers to Lighter user's manual

*** see "Input/Output specifications" on page 36

Muting Device

Sub-D, 25 pins, male, with shell.

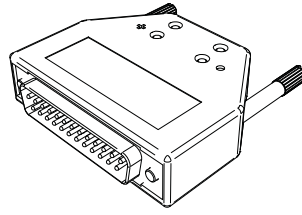

Figure 22: Command Box Muting Device provided



CAUTION: If the Command Box Muting Device provided is connected, the laser marker enable is bypassed.

Internal electric diagram

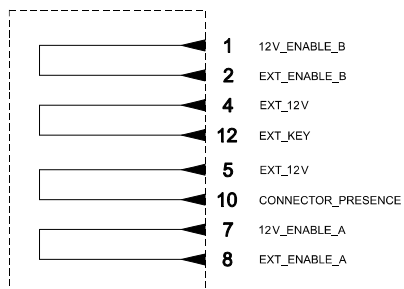

Figure 23: Command Box Muting Device electric diagram

X2 - Axes (I/O Control)

Control rack back panel connector

Plug Sub-D, 25 pins, male.

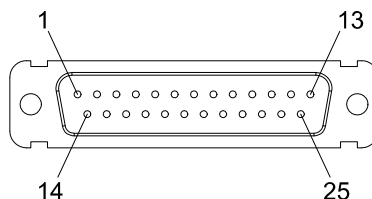

Figure 24: X2 - Axes connector, male panel plug (front view)

PIN	SIGNAL	TYPE**	DESCRIPTION
X2.1	EXT_12V	Output Power Supply	Auxiliary 12V DC power supply available for drive input logical HIGH (max 250mA)
X2.2	OUTPUT_0 (*) or STEP_Y	Digital Output	Generic output or Y-Axis drive step signal (Clock) for axis control
X2.3	OUTPUT_2 (*) or STEP_Z	Digital Output	Generic output or Z-Axis drive step signal (Clock) for axis control
X2.4	OUTPUT_4 (*) or BRAKE X	Digital Output	Generic output or X-Axis electromechanical brake release signal. ON during drive motion
X2.5	OUTPUT_6 (*) or BRAKE Y	Digital Output	Generic output or Y-Axis electromechanical brake release signal. ON during drive motion
X2.6	OUTPUT_8 (*) or BRAKE Z	Digital Output	Generic output or Z-Axis electromechanical brake release signal. ON during drive motion
X2.7	INPUT_0 (*) or ZERO X	Digital Input	Generic input or X-Axis home sensor input. The home search is stopped when this signal goes HIGH
X2.8	INPUT_1 (*) or ZERO Y	Digital Input	Generic input or Y-Axis home sensor input. The home search is stopped when this signal goes HIGH
X2.9	INPUT_2 (*) or ZERO Z	Digital Input	Generic input or Z-Axis home sensor input. The home search is stopped when this signal goes HIGH
X2.10	INPUT_3 (*) or DISABLE X	Digital Input	Generic input or X-Axis disable signal. When HIGH, the corresponding step signal remains in the status prior to activation
X2.11	INPUT_4 (*) or DISABLE Y	Digital Input	Generic input or Y-Axis disable signal. When HIGH, the corresponding step signal remains in the status prior to activation
X2.12	INPUT_5 (*) or DISABLE Z	Digital Input	Generic input or Z-Axis disable signal. When HIGH, the corresponding step signal remains in the status prior to activation
X2.13	GND	Ground	Ground reference
X2.14	OUTPUT_12 (*) or STEP R	Digital Output	Generic output or R-Axis drive step signal (Clock) for axis control
X2.15	OUTPUT_1 (*) or STEP X	Digital Output	Generic output or X-Axis drive step signal (Clock) for axis control
X2.16	OUTPUT_3 (*) or DIR Z	Digital Output	Generic output or Z-Axis drive direction signal
X2.17	OUTPUT_5 (*) or DIR Y	Digital Output	Generic output or Y-Axis drive direction signal

PIN	SIGNAL	TYPE**	DESCRIPTION
X2.18	OUTPUT_7 (*) or DIR X	Digital Output	Generic output or X-Axis drive direction signal
X2.19	INPUT 9	Digital Input	Generic Input
X2.20	INPUT 8	Digital Input	Generic Input
X2.21	INPUT_7 (*) or ZERO R	Digital Input	Generic input or R-Axis home sensor input. The home search is stopped when this signal goes HIGH
X2.22	INPUT_6 (*) or DISABLE R	Digital Input	Generic input or R-Axis disable signal. When HIGH, the corresponding step signal remains in the status prior to activation
X2.23	OUTPUT_9 (*) or BRAKE R	Digital Output	Generic output or R-Axis electromechanical brake release signal. ON during drive motion
X2.24	OUTPUT_11 (*) or DIR R	Digital Output	Generic output or R-Axis drive direction signal
X2.25	GND	Ground	Ground reference

Table 6: X2 - Axis connector pinout

* enabling an axis causes the corresponding control signals to no longer be available as generic inputs/outputs. Refer to Lighter user's manual, "Setting the X, Y, Z, and Rotor Axes parameters" to enable/disable Axes and set the Axes properties

** see "Input/Output specifications" on page 36

RS232



NOTE: Depending on the system S/N the serial port can be mapped as COM2 or COM3. Contact Datalogic Technical Support for more details (see “Technical Support” on page vii for contact details).

Control rack back panel connector

Plug Sub-D, 9 pins, male.

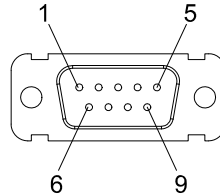

Figure 25: RS232 connector, male panel plug (front view)

PIN	SIGNAL	TYPE	DESCRIPTION
1	DCD	Input	Data Carrier Detect
2	RXD	Input	Receive Data
3	TXD	Output	Transmit Data
4	DTR	Output	Data Terminal Ready
5	GND	Ground	Ground reference
6	DSR	Input	Data Set Ready
7	RTS	Output	Request to Send
8	CTS	Input	Clear to Send
9	RI	Input	Ringing Indicator

Table 7: RS232 connector pinout

Encoder

Control rack back panel connector

Socket, M12, 8 pins female. Recommended encoder: incremental Encoder PNP, M12, 8 pins, push/pull outputs AB0 only, 10-30 VDC.

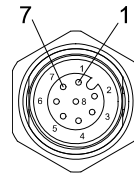

Figure 26: Encoder connector, female panel socket (front view)

PIN	SIGNAL	TYPE*	DESCRIPTION
1	GND	Ground	Ground reference
2	VCC	Power Output	Auxiliary 12V DC power supply
3	ENC_A	Digital Input	Encoder HTL A channel signal
4	GND	Ground	Return signal for ENC_A
5	ENC_B	Digital Input	Encoder HTL B channel signal
6	GND	Ground	Return signal for ENC_B
7	RESERVED	-	DO NOT CONNECT
8	RESERVED	-	DO NOT CONNECT
BODY	SHIELD	Shield	Shield

Table 8: Encoder connector pinout

Photocell

Control rack back panel connector

Panel socket BINDER, M12, 4 pins female, 763 series. Recommended photocell: Datalogic S51-PA-5-B01-PK; Datalogic S15-PA-5-B01-PK or equivalent.

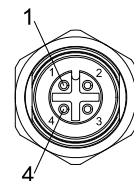

Figure 27: Photocell connector, female panel socket (front view)

PIN	SIGNAL	TYPE*	DESCRIPTION
1	VCC	Power Supply	Auxiliary 12V DC power supply
2	RESERVED	-	DO NOT CONNECT
3	GND	Ground	Ground reference
4	PHOTOCELL	Digital Input	PNP photocell signal

Table 9: Photocell connector pinout



CAUTION: For EMC compliance a RICHCO RRC-16-9-28-M2-K5B ferrite (or equivalent) must be used.

INPUT/OUTPUT SPECIFICATIONS

Digital Input

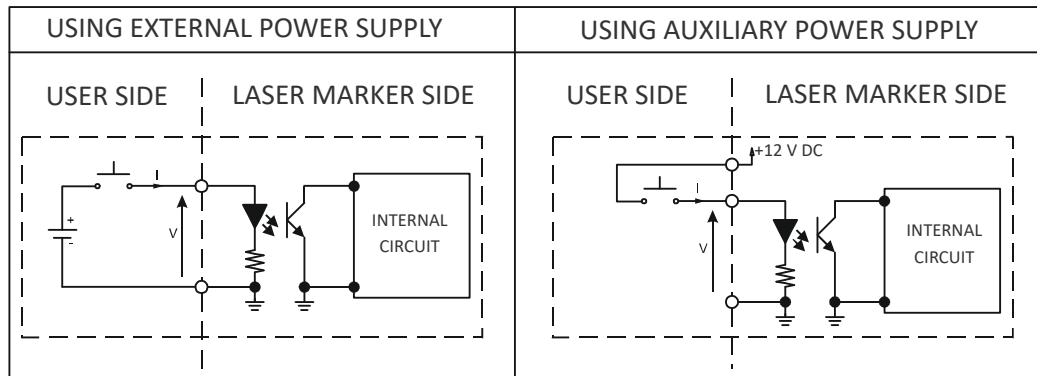

TECHNICAL CHARACTERISTICS			
Type	Optocoupler		
Vmax	24 V DC		
Imax	5 mA @ 24 V DC		
Pulse Width	≥ 1 ms (debounce)		
	MIN	TYP	MAX
INPUT Logic LOW	0.0 V DC	0.0 V DC	2.0 V DC
INPUT Logic HIGH	5.0 V DC	12.0 V DC	24.0 V DC

Table 10: Digital Input specification

Digital Output

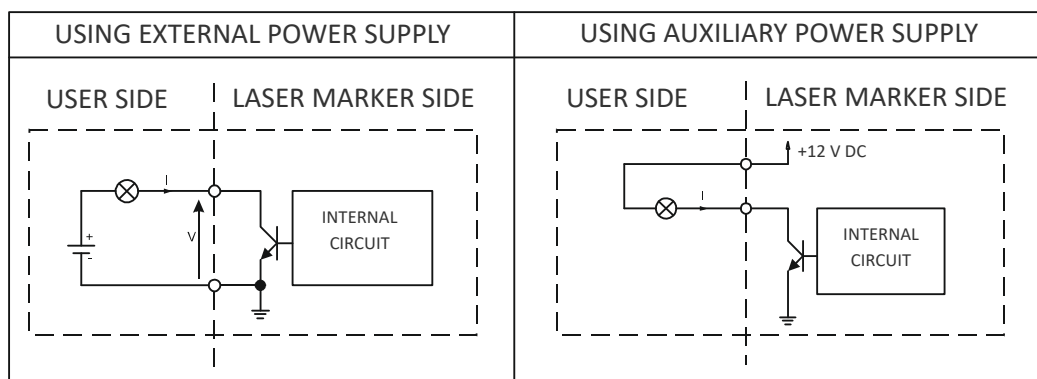





TECHNICAL CHARACTERISTICS	
Type	Low side driver
Vmax	24 V DC
Imax	250 mA
Vsaturation	<0.5 V DC
Leakage current	< 5 μA
OUTPUT State ON	V ≤ 0.5 V DC; I ≤ 250 mA
OUTPUT State OFF	V ≤ 24 V DC; I ≤ 5 μA

Table 11: Digital Output specification

LASER MARKER STATE

Normal Operation States

STATE	DESCRIPTION	STATUS LED
SYSTEM BOOTING UP	This state occurs since the laser marker is switched on until Laser Engine has been loaded and no errors occurred	 Blinking
WAIT FOR START	In this state the laser marker cannot emit UV lasers radiation and Aiming beam cannot be activated	 Steady
WARMING UP	In this state the laser marker is performing the warm up process	 Blinking
STANDBY SHUTTER CLOSED	In this state Aiming and Focus beam can be activated while the laser marker cannot emit UV laser radiation	 Steady
READY	In this state the laser marker is able to emit UV laser radiation	 Steady

Error States

STATE	DESCRIPTION	STATUS LED
ERROR	This state occurs if the laser marker detects an error that prevents normal operation	 Blinking

SYSTEM ERROR	DESCRIPTION
INTERLOCK ERROR	This error occurs if the INTERLOCK function is ON. To reset the error, set INTERLOCK function to OFF and repeat the turning on sequence This error occurs if the CONNECTOR_PRESENCE signal (pin 10 Command Box connector) is LOW or not connected. To reset the error, set CONNECTOR_PRESENCE signal to HIGH value and repeat the turning on sequence
TEMPERATURE ERROR	This error occurs if the temperature inside the laser source is out of the operating temperature range. To reset the error, a Laser marker restart is required
MASTER OSCILLATOR ERROR	This error occurs if the laser source detects an internal failure. To reset the error, a Laser marker restart is required

Warning State

STATE	DESCRIPTION	STATUS LED
WARNING INVALID START SEQUENCE	This state occurs if the turning on sequence has not been followed. To restore normal laser marker operation, repeat the turning on sequence	 Blinking















Control the Laser Marker States

The laser marker states can be controlled by:

- **Key and Enable Selector**
- **X1 - Command Box connector**















Key and Enable Selector mode

Controlling the laser marker states using the *Key and Enable Selector* on the control rack front panel requires that the input signals of the *X1 - Command Box* connector **X1.12** (*EXT_KEY*), **X1.8** (*EXT_ENABLE_A*) and **X1.2** (*EXT_ENABLE_B*) are set to fixed **HIGH** level:

STATE	COMMAND BOX INPUT STATE		KEY SELECTOR	ENABLE SELECTOR	STATUS LED
SYSTEM BOOTING UP	EXT_KEY	HIGH			
	EXT_ENABLE_A	HIGH			
	EXT_ENABLE_B	HIGH			
WAIT FOR START	EXT_KEY	HIGH			
	EXT_ENABLE_A	HIGH			
	EXT_ENABLE_B	HIGH			
WARMING UP	EXT_KEY	HIGH			
	EXT_ENABLE_A	HIGH			
	EXT_ENABLE_B	HIGH			
STANDBY SHUTTER CLOSED	EXT_KEY	HIGH			
	EXT_ENABLE_A	HIGH			
	EXT_ENABLE_B	HIGH			
READY	EXT_KEY	HIGH			
	EXT_ENABLE_A	HIGH			
	EXT_ENABLE_B	HIGH			

Command Box mode

Controlling the laser marker states using the *X1 - Command Box* connector on the control rack back panel requires that the *Key Selector* and *Enable Selector* are set to fixed position **1**:

STATE	COMMAND BOX INPUT STATE		KEY SELECTOR	ENABLE SELECTOR	STATUS LED
SYSTEM BOOTING UP	EXT_KEY	LOW			
	EXT_ENABLE_A	LOW			
	EXT_ENABLE_B	LOW			
WAIT FOR START	EXT_KEY	LOW			
	EXT_ENABLE_A	LOW			
	EXT_ENABLE_B	LOW			
WARMING UP	EXT_KEY	HIGH			
	EXT_ENABLE_A	LOW			
	EXT_ENABLE_B	LOW			
STANDBY SHUTTER CLOSED	EXT_KEY	HIGH			
	EXT_ENABLE_A	LOW			
	EXT_ENABLE_B	LOW			
READY	EXT_KEY	HIGH			
	EXT_ENABLE_A	HIGH			
	EXT_ENABLE_B	HIGH			

TIMING DIAGRAMS

Turning On sequence

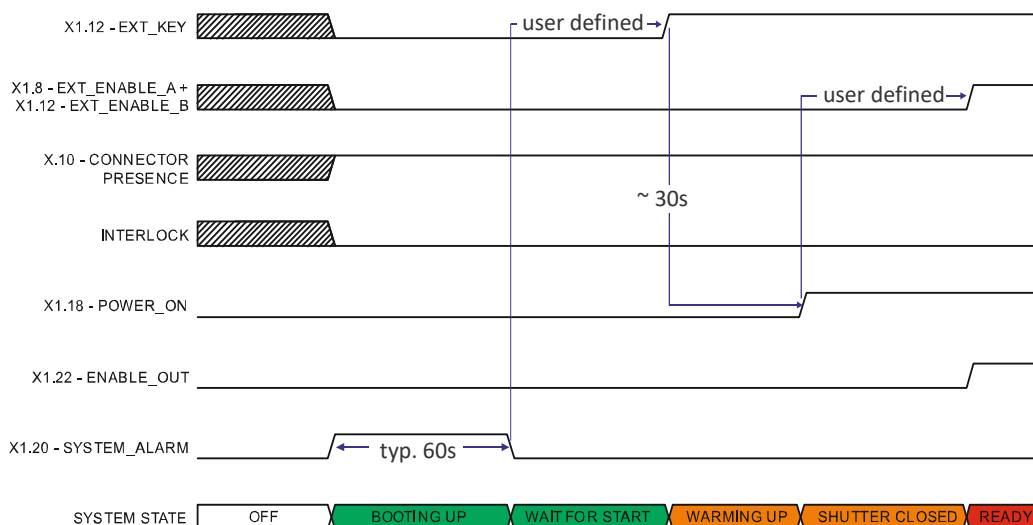

Figure 28: Turning On sequence timing diagram

Marking control signals behavior

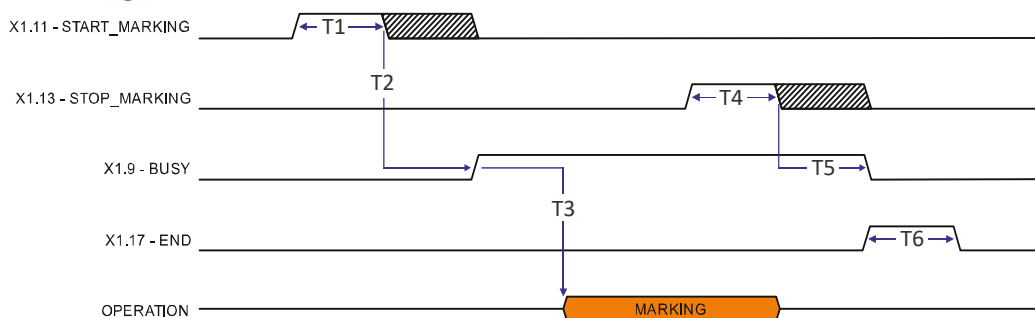

Figure 29: Marking process timing diagram

REF.	NAME	DESCRIPTION
T1	Start Time	Minimum time duration that the START_MARKING signal must have in order to be accepted as a valid START_MARKING event
T2	Start Delay	Delay between the acceptance of the START_MARKING signal and the rising edge of the BUSY signal
T3	Busy Advance	Delay between the rising edge of the BUSY signal and the laser emission
T4	Stop Time	Minimum time duration that the STOP_MARKING signal must have in order to be accepted as a valid STOP_MARKING event
T5	Busy Delay	Delay between the end of the laser emission and the falling edge of the BUSY signal
T6	End Time	Time duration of the END signal



NOTE: Consult Lighter™ software user's manual for a proper use of the same.

MARVIS™ I/O signals behavior

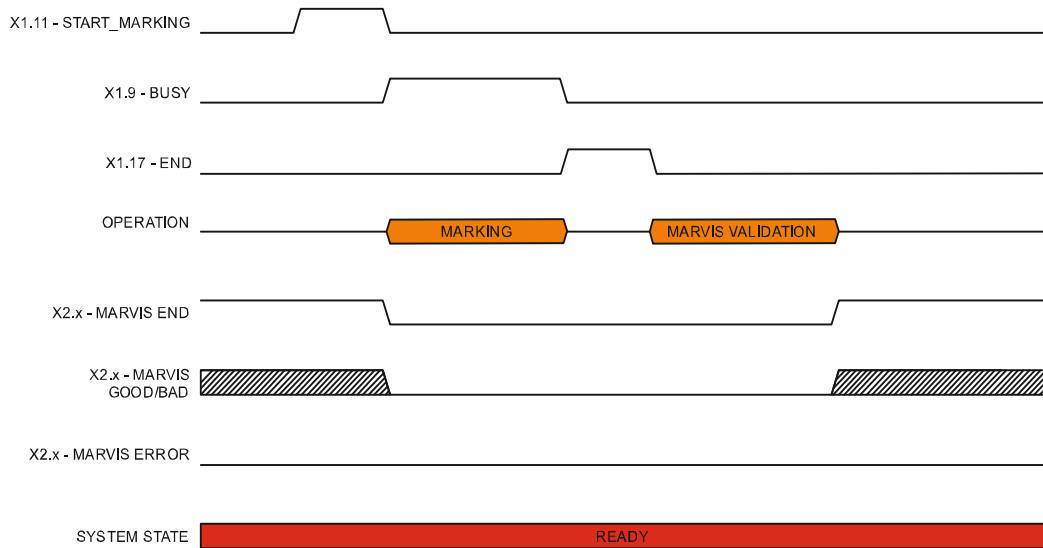

Figure 30: MARVIS™ I/O signals behavior

Axes I/O signals behavior

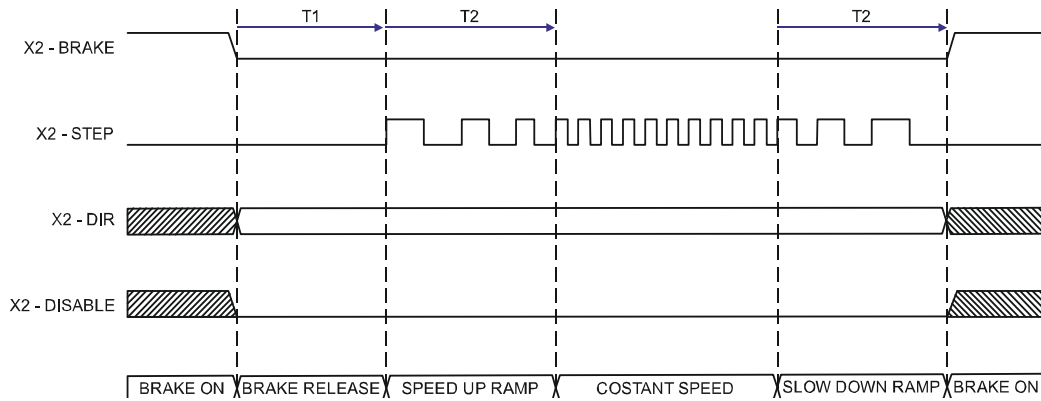

Figure 31: Axes I/O signals behavior

REF.	NAME	DESCRIPTION
T1	Brake release	The time that elapses between the brake release signal activation and the start of mechanical movement
T2	Ramp Time	The time to go from minimum speed (Start speed) to working speed (Speed)

LIGHTER™ SUITE MARKING SOFTWARE

The laser marker is equipped with Lighter™ Suite marking software.

Lighter™ Suite is the all-inclusive editing and laser management software for all Datalogic Laser Marking products.

Lighter™ Suite with its innovative approach focused on the user experience is revolutionizing Laser Marking management; the powerful and simple interface, the flexible and comprehensive customization capabilities and effective production tools represent an important step-ahead in traceability and branding industrial applications.

Lighter™ Suite combines into an unified GUI (Graphical User Interface) a powerful vectorial graphical editor, an advanced laser controller and the innovative MARVIS™ (Mark Read Verify Integrated Solution) feature to seamless interact with AutoID code reader for in-line validation of marked traceability codes.

MARVIS™ connects Datalogic MATRIX™ N-series reader with the laser marker, enabling controlling from one single interface and enhancing individual products' performances.

MARVIS™ is also available as update for existing products.

Object-Oriented Configuration

In the Lighter Suite, each object is associated with specific LASER parameters and READER configuration; loading a graphical layout will automatically retrieve and update laser and reader configurations.

Advanced Editing Function



- Easily create, import and edit texts, shapes and logos
- One-click code generator for 1D and 2D symbologies
- Object-related Property Browser for fast adjustment of Marker and Reader parameters
- Imports Bitmap and Vector files (DXF, DWG, PLT, PDF, AI, SVG, BMP, JPG, PNG and TIFF...)
- Advanced filling featured with various laser-optimized patterns

MARVIS™ Integrated Configuration And Setup

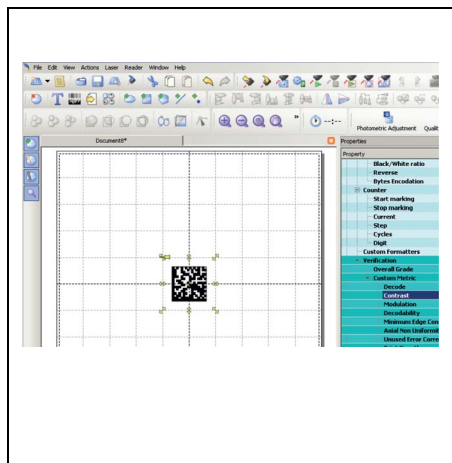

- IP address discovery and connection management
- Dedicated Digital output for in-line parts selection
- Dedicated Digital input for deferred reader trigger
- Configurable images storage pool
- New Code Quality Training feature to automatically define code quality threshold from "Golden Sample"
- Patent Pending "Quality Grade Metric Profile" (QGP)

Connectivity

The Lighter™ Suite allows OEMs and Machine builders to develop a complete and cost effective Laser Marking Station, based on embedded hardware and software resources (such as STAND ALONE mode) or to design an advanced Laser Marking Solution able to control machinery over a simple Ethernet connection with a supervisor computer (MASTER-SLAVE mode).

Lighter™ Suite natively embeds TcpServer, Profinet I/O and EtherNet/IP protocols.

Scripting programmability

The Lighter™ Suite integrates the IDE (Integrated Development Environment) providing the users with a full set of tools to be used for extremely flexible customization.

The programming language is ECMAScript (also called JavaScript).

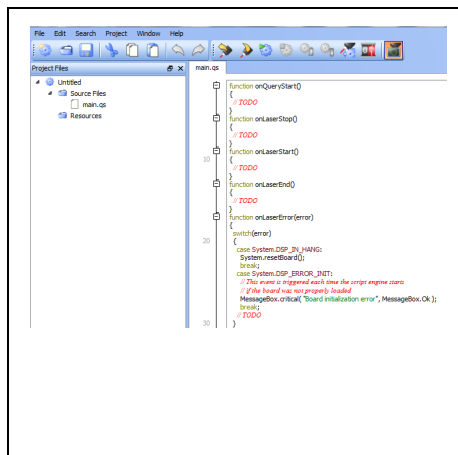
 <pre> function onQueryStart() { // TODO } function onLaserStop() { // TODO } function onLaserStart() { // TODO } function onLaserEnd() { // TODO } function onLaserError(error) { switch(error) { case System_DSP_IN_HANG: System.messageBox(); break; case System_DSP_ERROR_INTERRUPT: // This event is triggered each time the script engine starts // if this board has not properly finished MessageBox.critical("Board initialization error", MessageBoxButtons.Ok); break; // TODO } } </pre>	<ul style="list-style-type: none"> • Control the entire marking process • Create and fully customize marking layout and its content at runtime • Interact with local or centralized databases • Create alternative customized interfaces • Interact with Third Party devices
--	---

Runtime Production Statistics and Reports

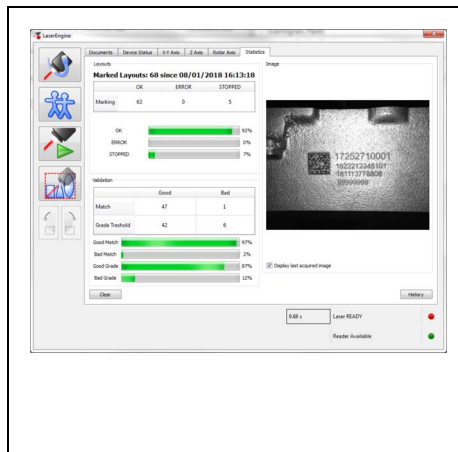
 <p>Marked Layouts: 68 since 08/01/2018 16:13:18</p> <table border="1"> <tr> <td>OK</td> <td>63</td> <td>0</td> <td>5</td> </tr> </table> <p> OK: 92% ERROR: 0% STOPPED: 7% </p> <table border="1"> <tr> <td>relation</td> <td>Good</td> <td>Bad</td> </tr> <tr> <td>Match</td> <td>47</td> <td>1</td> </tr> <tr> <td>Grade Threshold</td> <td>42</td> <td>6</td> </tr> </table> <p> Good Match: 92% Bad Match: 0% Good Grade: 87% Bad Grade: 12% </p> <p> <input type="checkbox"/> Check last acquired image <input type="button" value="Clear"/> <input type="button" value="History"/> </p> <p> <input type="button" value="Eject"/> Laser READY Reader Available </p>	OK	63	0	5	relation	Good	Bad	Match	47	1	Grade Threshold	42	6	<p>Built-in validation statistics dashboard.</p> <p>Configurable log file with Quality Reporting and code images.</p>
OK	63	0	5											
relation	Good	Bad												
Match	47	1												
Grade Threshold	42	6												

CHAPTER 4

SET UP

CONNECTIONS

The laser marker connections are described here below. Follow the operations as described.

Fans installation

The fans supplied with the laser marker must be accurately positioned and fixed on the resonator so that they can work properly.

The fans must be assembled so that the air flow is aimed at the unit containing the crystal (gold-colored section on the resonator).

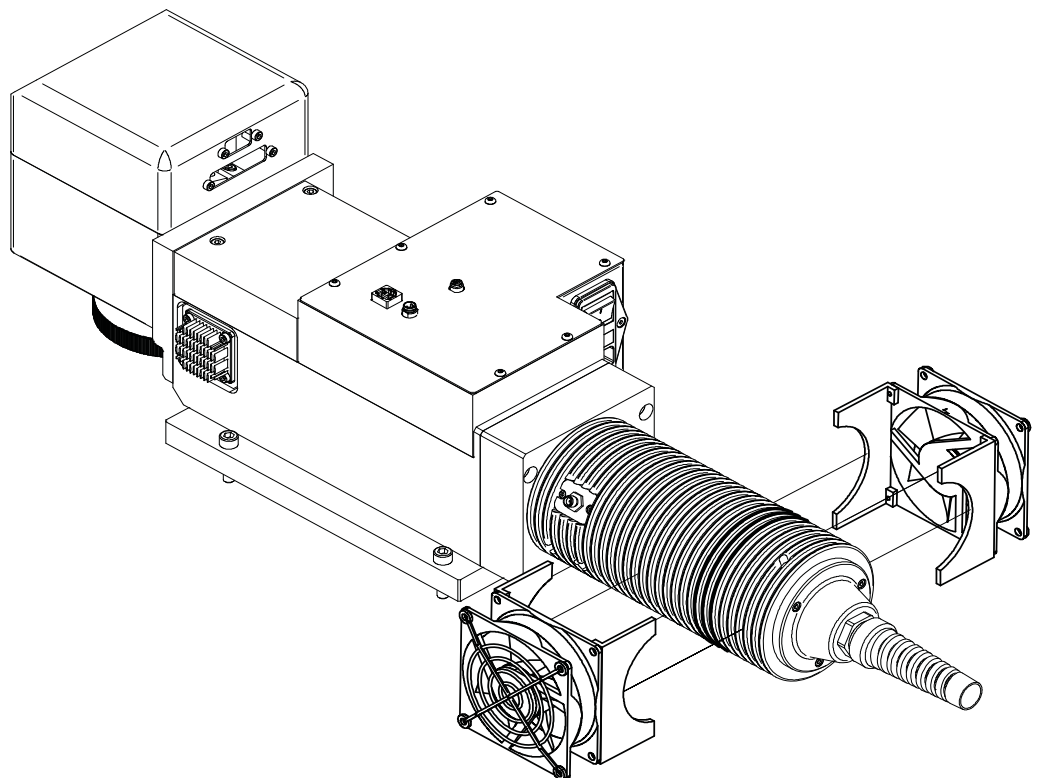

Figure 32: Fans installation

Connecting X1 - Command Box connector

The *X1 - Command Box connector* must always be inserted with proper signals provided in order to use the laser marker. The absence of such connector blocks the laser marker operations.



WARNING: If the Command Box Muting Device provided is connected, the laser marker enable is bypassed.

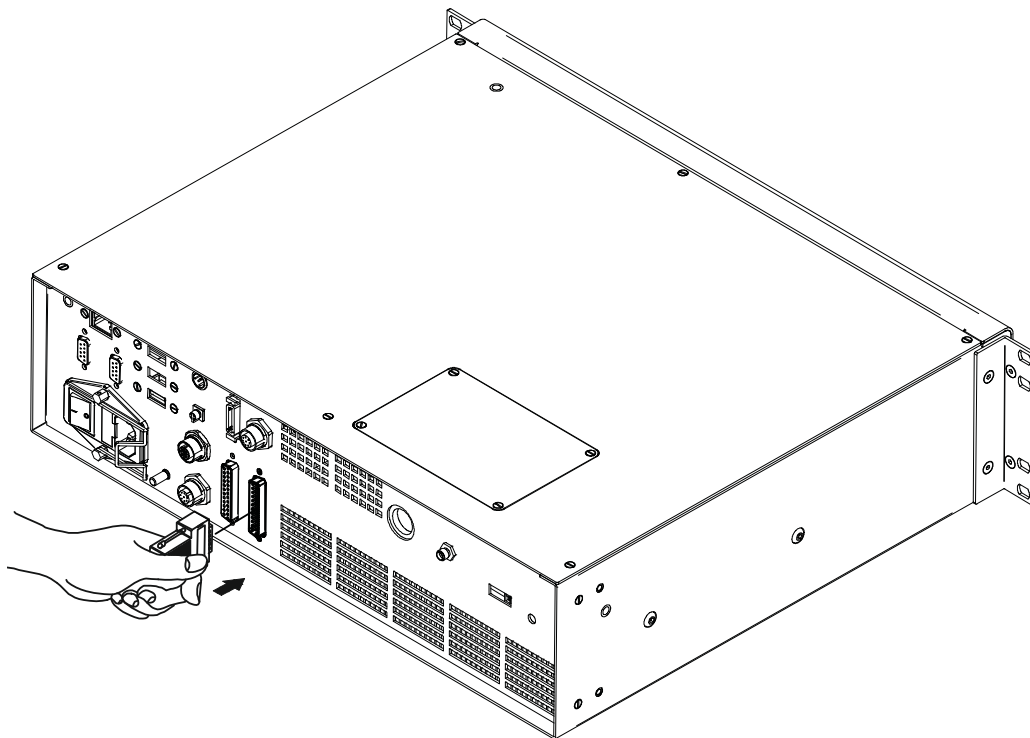

Figure 33: Connecting X1 - Command Box connector

Connecting Interlock connector

The *Interlock connector* must always be inserted with properly signals provided in order to use the laser marker. The absence of such connector blocks the laser emission.



CAUTION: Do not use the Interlock Muting Device for external devices, since this will result in loss of the safety function of the machine to which this product is installed.

Do not use the Interlock Muting Device except for maintenance of this product.



CAUTION: It is the customer's responsibility to provide a correct integration of the safety signals according to applicable regulations.

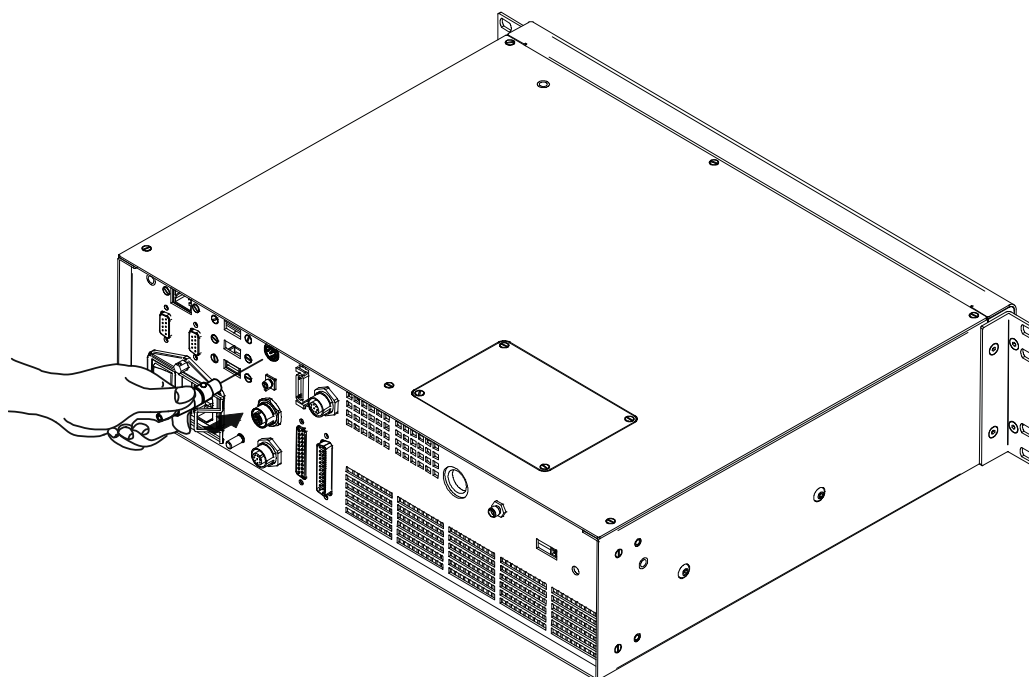

Figure 34: Connecting Interlock connector

Connecting Interlock Out connector

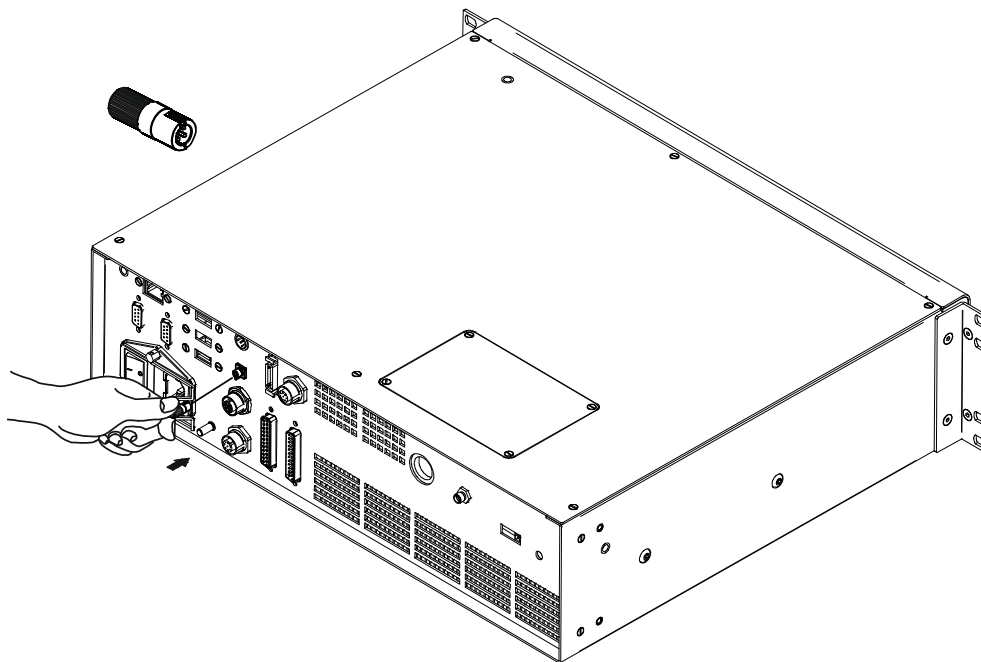

Figure 35: Connecting Interlock Out connector

Connecting the Optical Fiber to the control rack

Follow the steps listed here below to connect the optical fiber to the control rack:

1. unscrew the four screws holding the cover plate on the control rack.

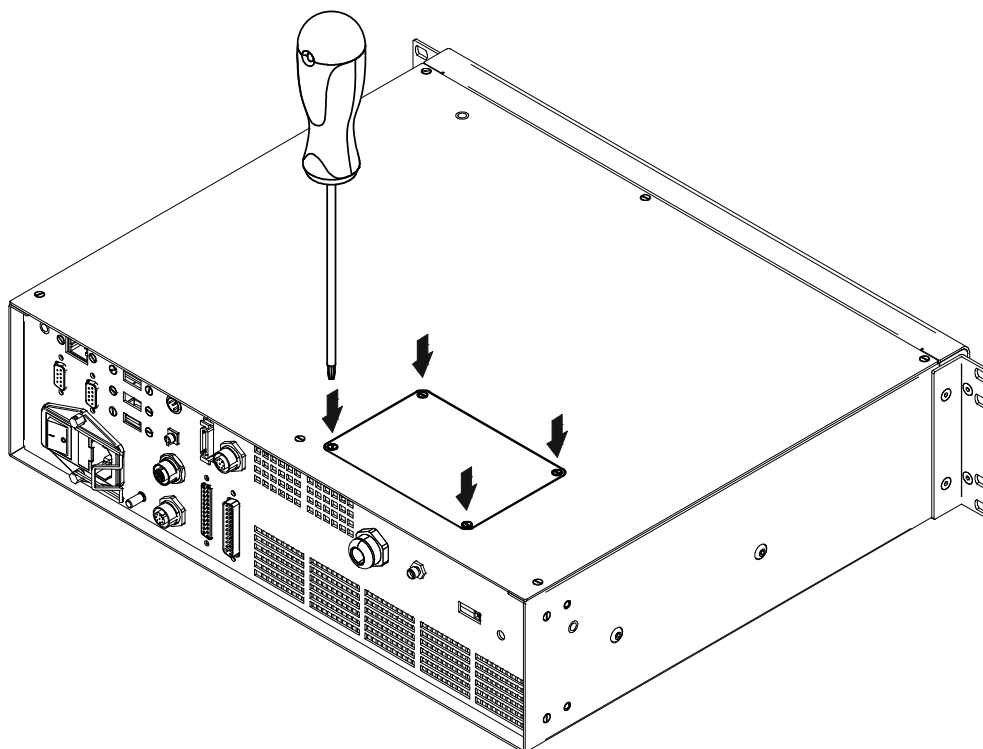

Figure 36: Removing the cover plate from the control rack

- insert the optical fiber into the cable gland **without** removing its **protection cap**.



CAUTION: The insertion of the optical fiber is a delicate operation. You must make sure that the optical fiber is protected by its cap during insertion through the cable gland to avoid damaging or dirtying it.

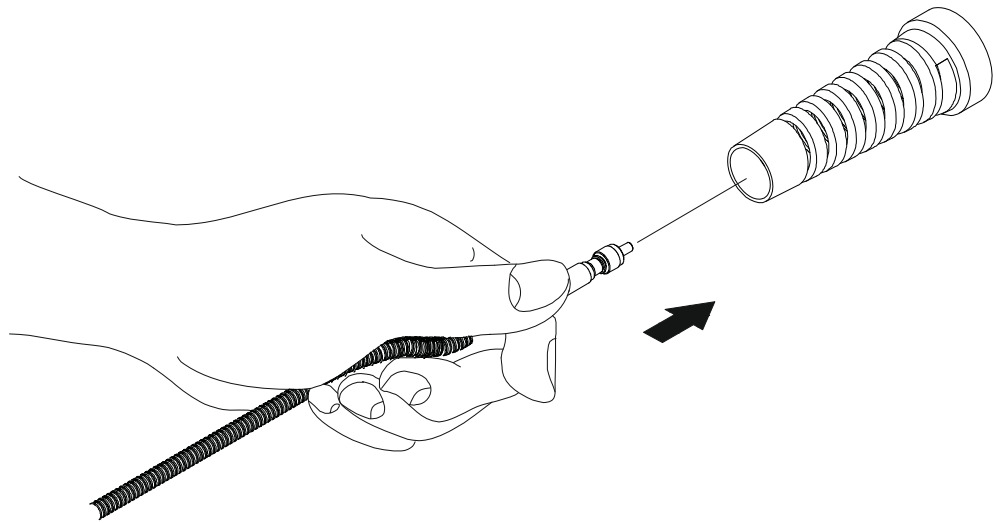

Figure 37: Passing the optical fiber through the cable gland

- insert the optical fiber into the PG cable gland mounted on the rear panel of the control rack **without** removing the **protection cap**.

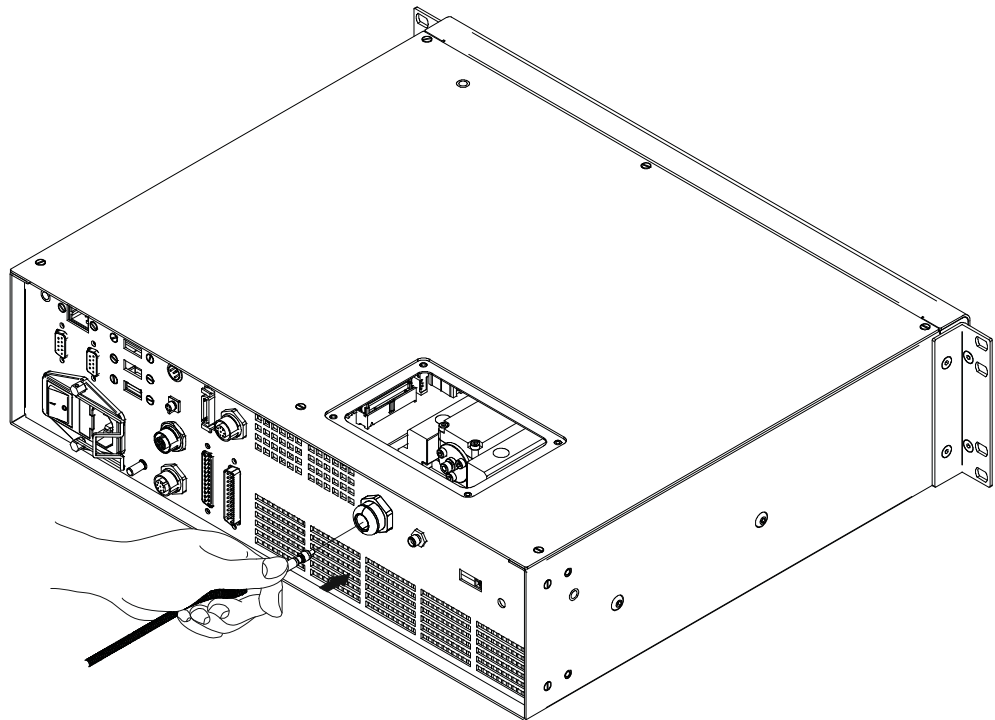

Figure 38: Passing the optical fiber through the PG cable gland

4. **remove** the optical fiber **protection cap** and tighten it to the fiber diode module paying attention not to soil or scratch the fiber end. Tighten the hexagonal nut of the fiber by hand, until resistance to rotation is felt.

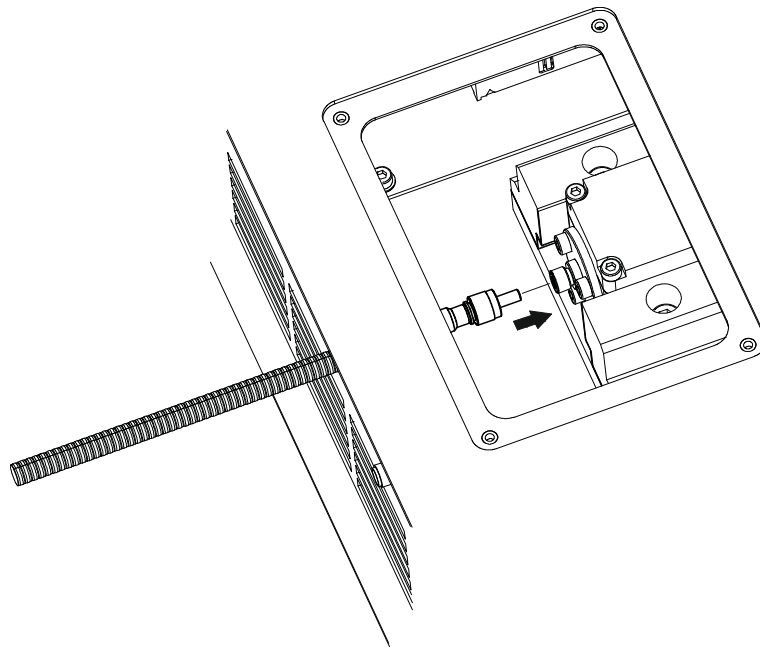

Figure 39: Connection of the optical fiber



NOTE: It is recommended to store the protective caps in a safe place in case it should be necessary to pack the product again.

5. fix the cable gland to the PG cable gland on the rack.

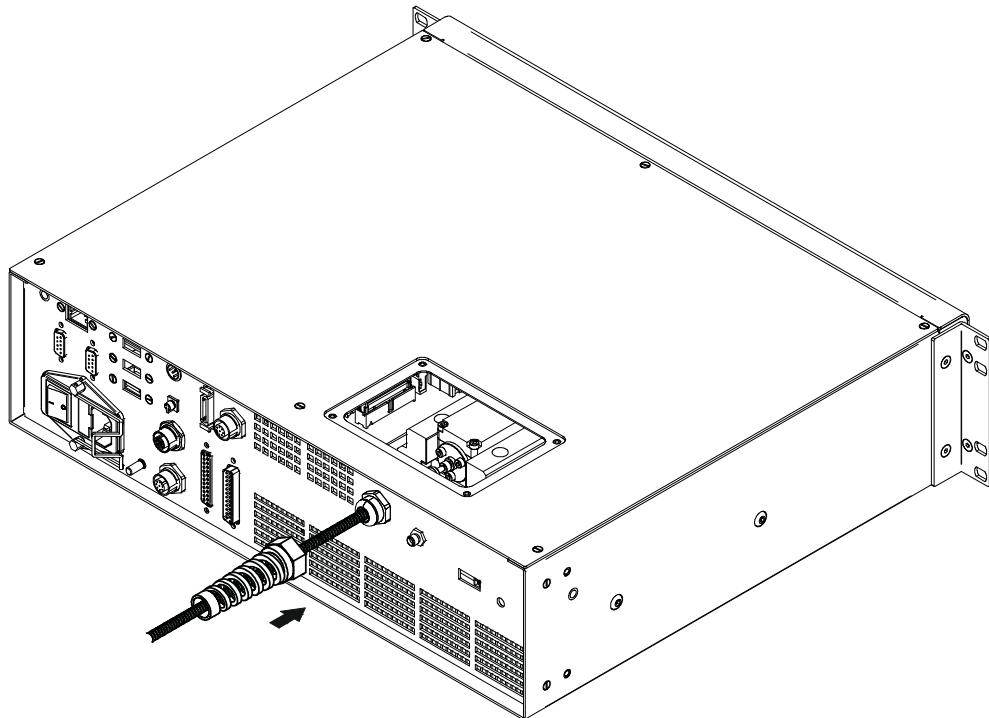

Figure 40: Fixing the cable gland

- close the rack cover plate.

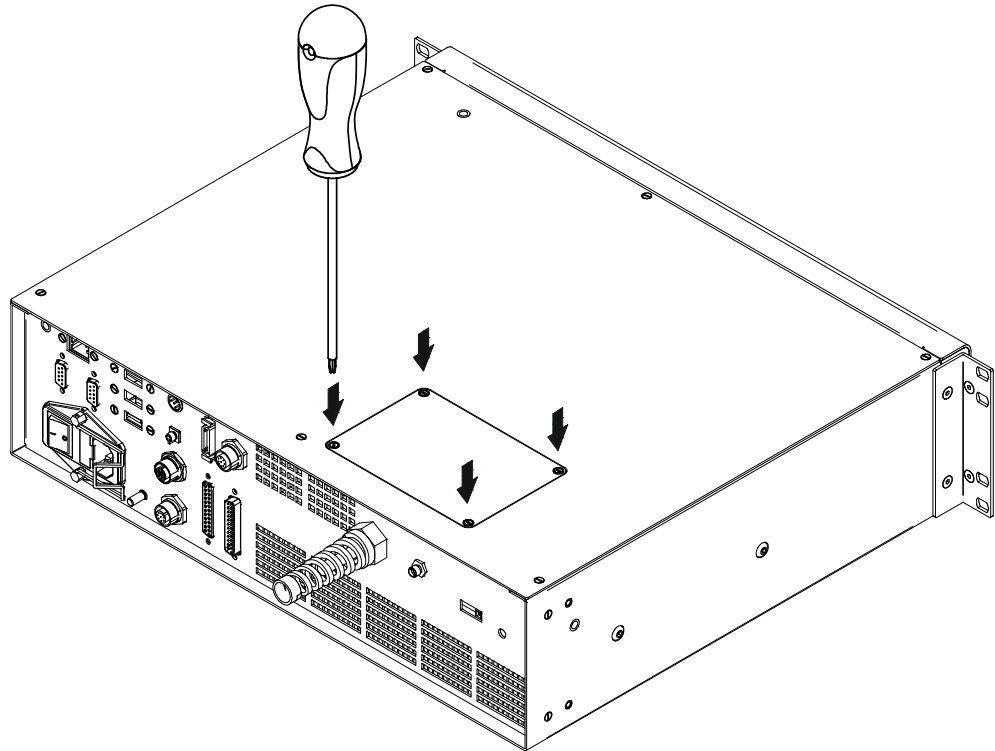

Figure 41: Closing cover

Connecting the Optical Fiber on the resonator

Follow the steps listed here below to wire the optical fiber to the resonator:

- unscrew the three screws that secure the metallic cover and cable gland to the resonator.

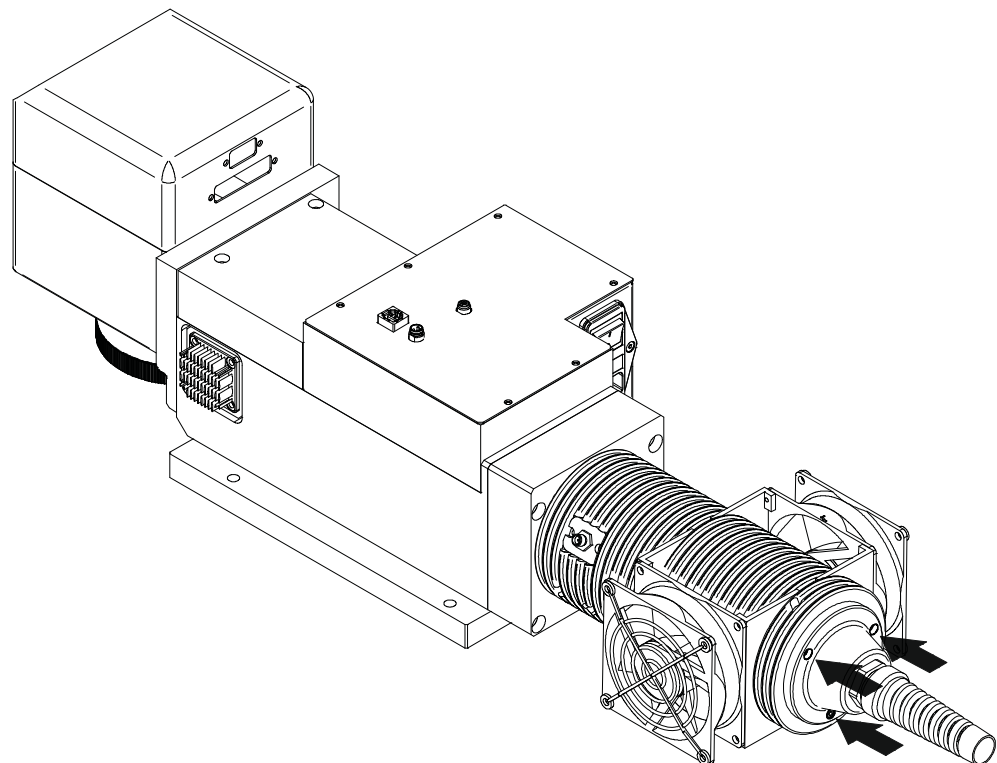

Figure 42: Disassembling the optical fiber cable gland from the resonator

2. insert the optical fiber through the cable gland **without** removing the **protection cap**.



CAUTION: The insertion of the optical fiber is a delicate operation. You must make sure that the optical fiber is protected by its cap during insertion through the cable gland to avoid damaging or dirtying it.

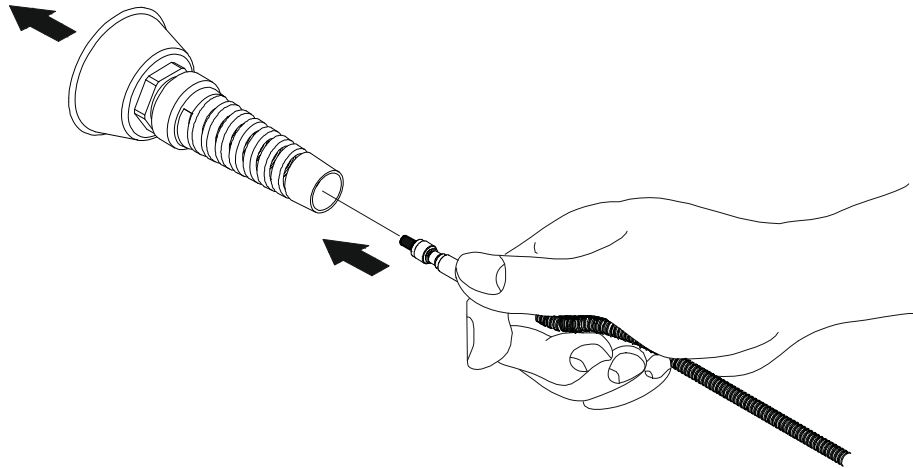

Figure 43: Passing the optical fiber through the cable gland

3. **remove the protection cap** and insert the optical fiber in the resonator, being careful not to soil or scratch the fiber end. Tighten the hexagonal nut of the fiber by hand, until resistance to rotation is felt.

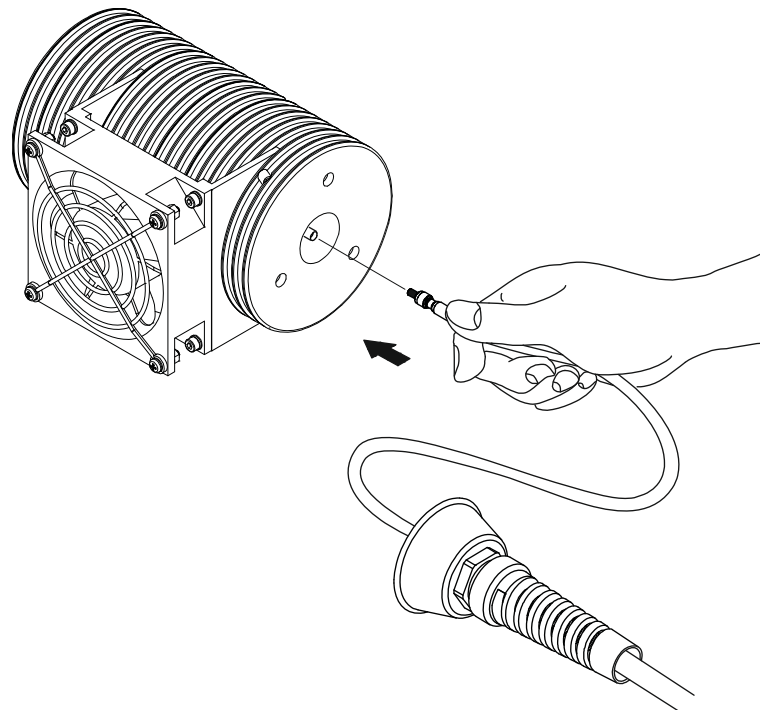

Figure 44: Connecting the optical fiber to resonator



NOTE: It is recommended to store the protective caps in a safe place in case it should be necessary to pack the product again.

4. screw the metallic cover and cable gland onto the resonator.

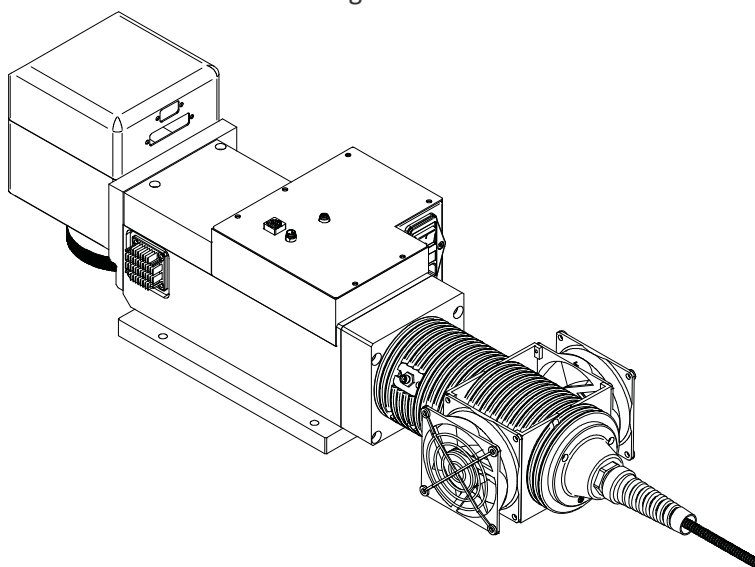

Figure 45: Final closing



CAUTION: To avoid damaging or breaking the optical fiber, never subject it to a bending radius smaller than 20 cm.

Connecting Radiofrequency cable

Screw in the SMA cable connectors, starting at the resonator side (90° end) then at the rack side.

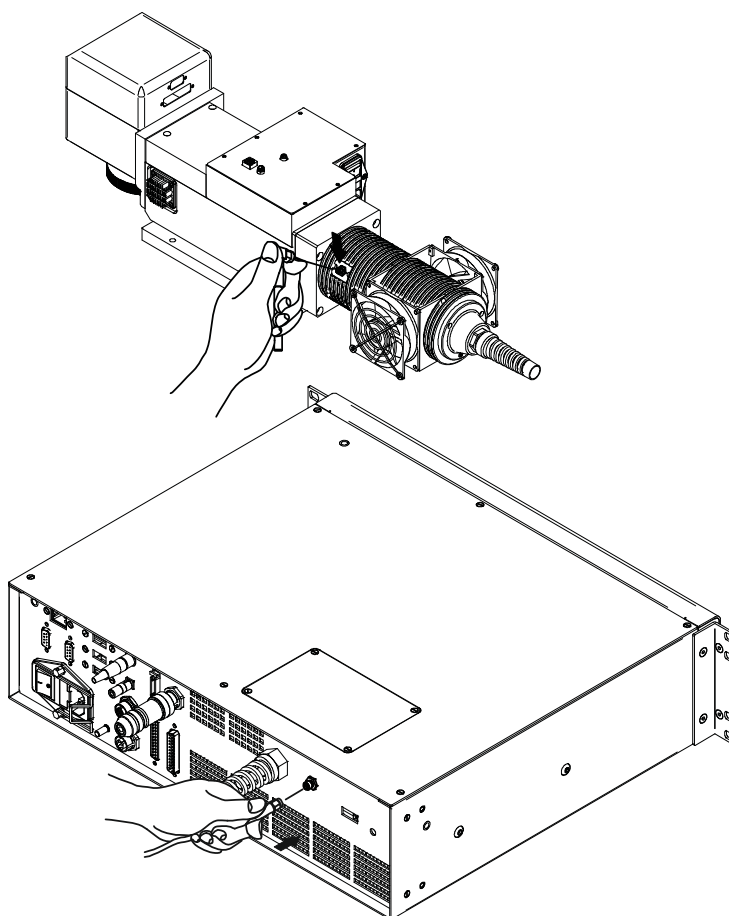

Figure 46: RF cable connection

Connecting MDR cable

Connect the MDR cable to the rack:

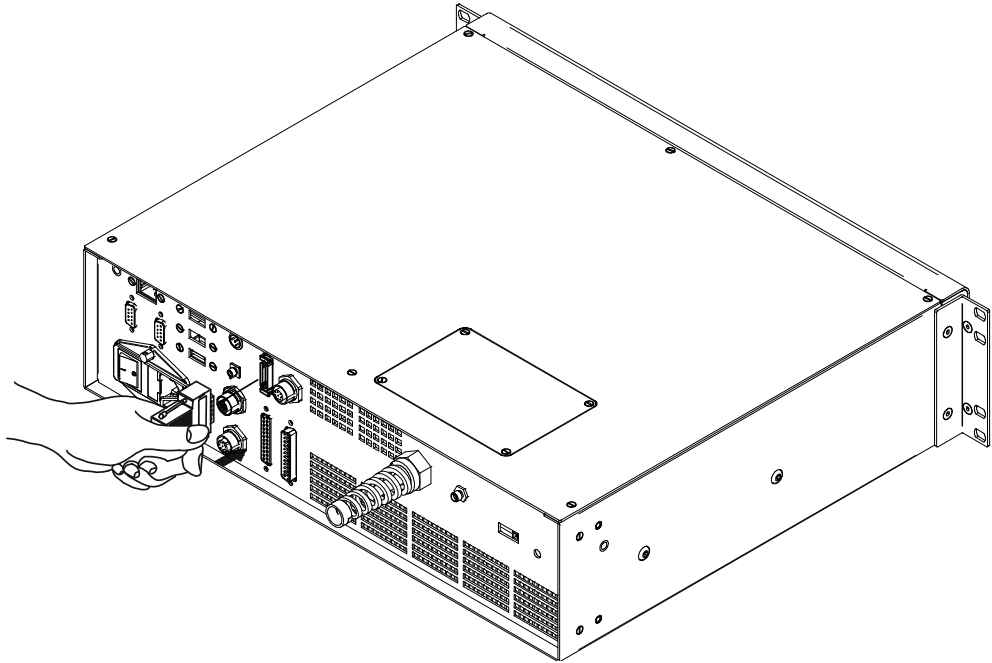

Figure 47: MDR connection control rack side

Connect the other end of the cable to the scanner head.

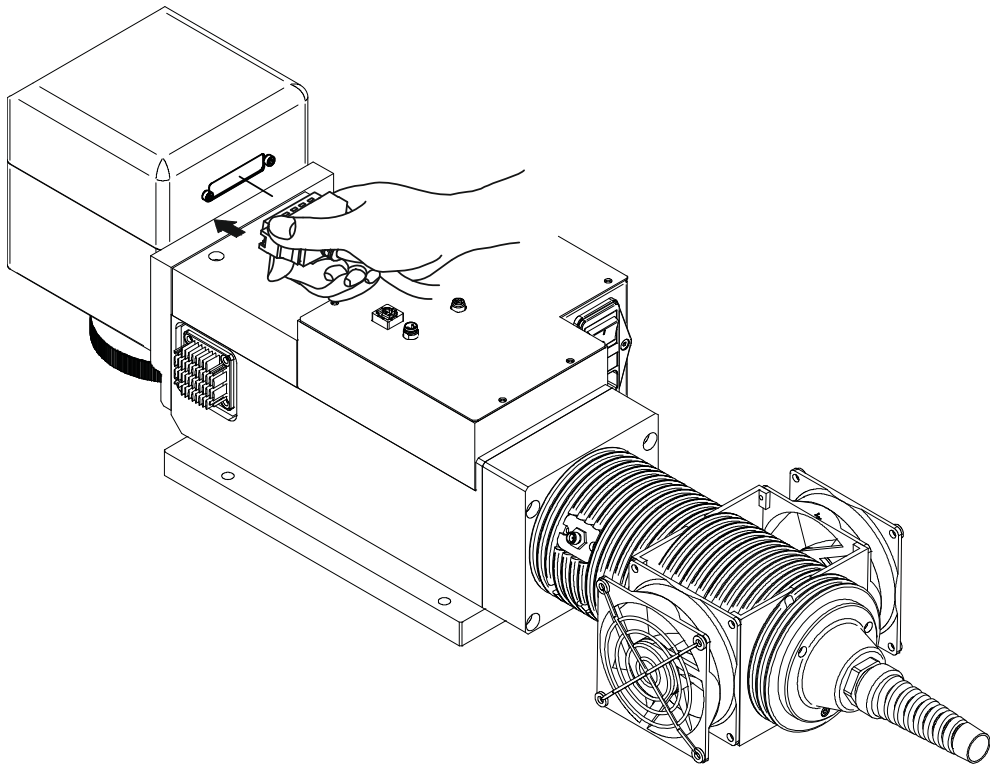

Figure 48: MDR connection resonator side

Connecting Resonator cable

Connect the resonator cable to the rack:

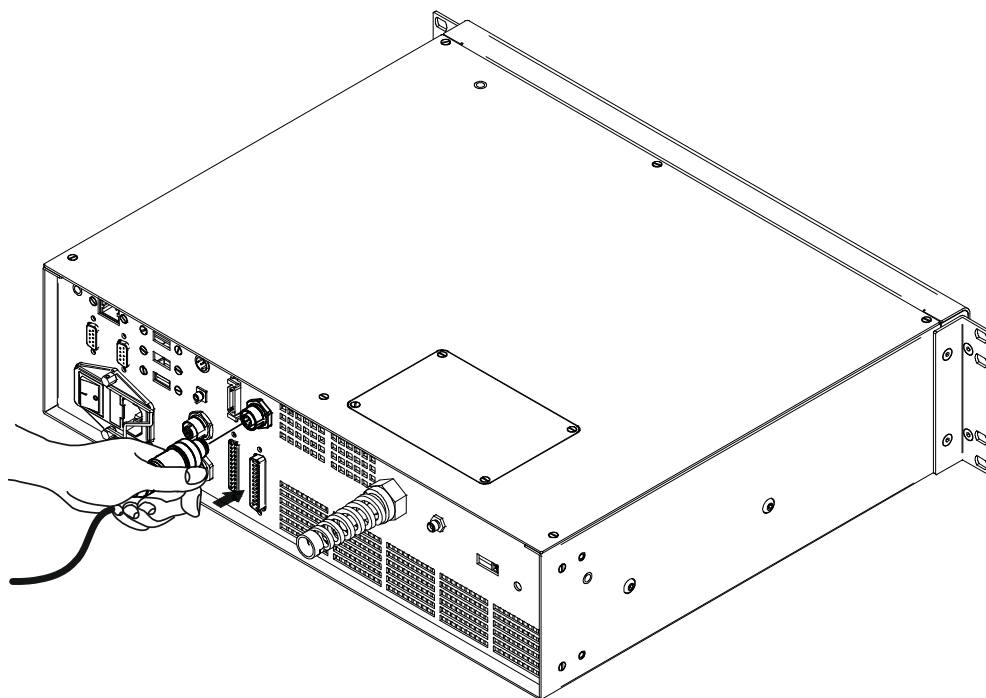

Figure 49: Resonator cable connection rack side

Connect the other end of the cable to the resonator.

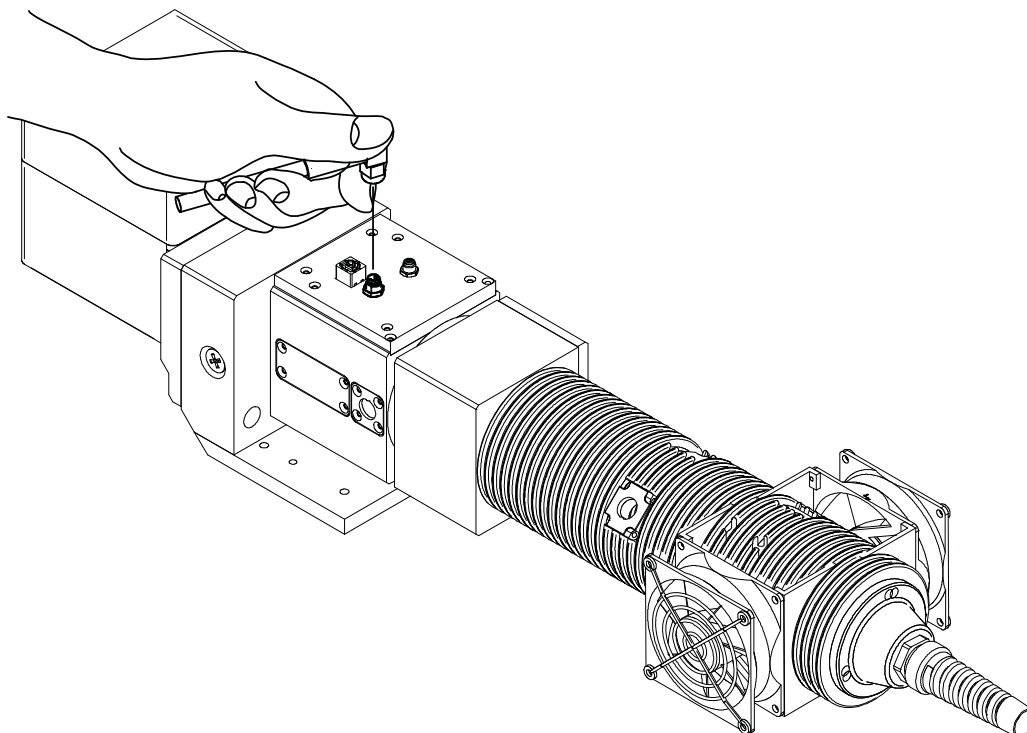

Figure 50: Resonator cable connection resonator side

Connecting Fan cable

Connect the fan cable to the resonator.

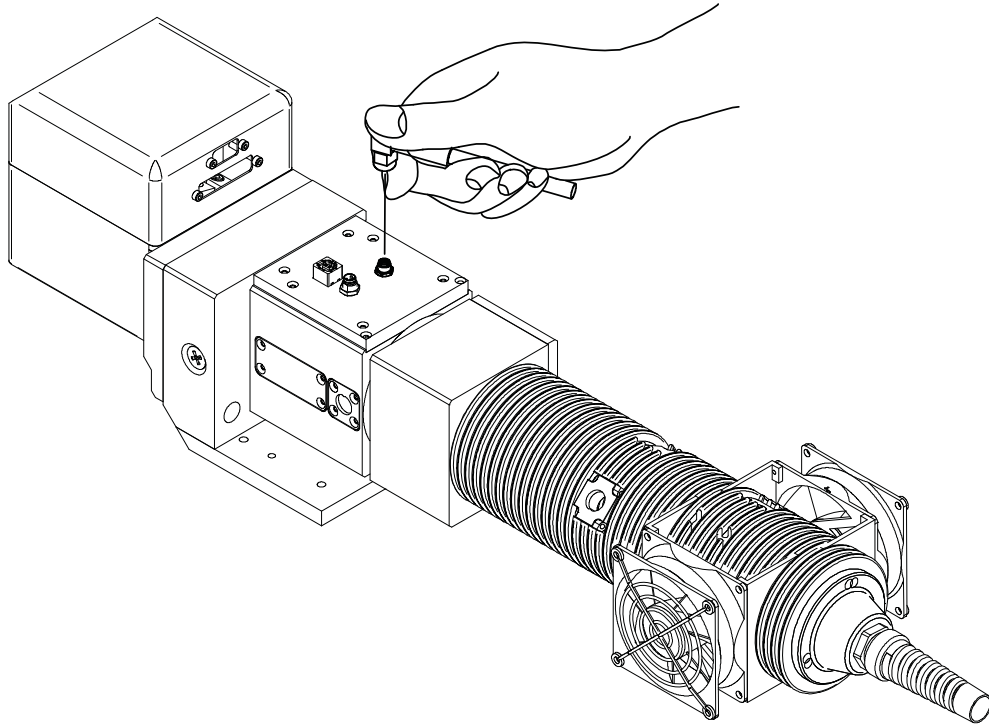

Figure 51: Resonator fan cable connection

Connecting Power Supply cable

Connect the Power Supply cable using the cord retention system.



CAUTION: Lock the plug with the retaining clamp to avoid accidental disconnection.

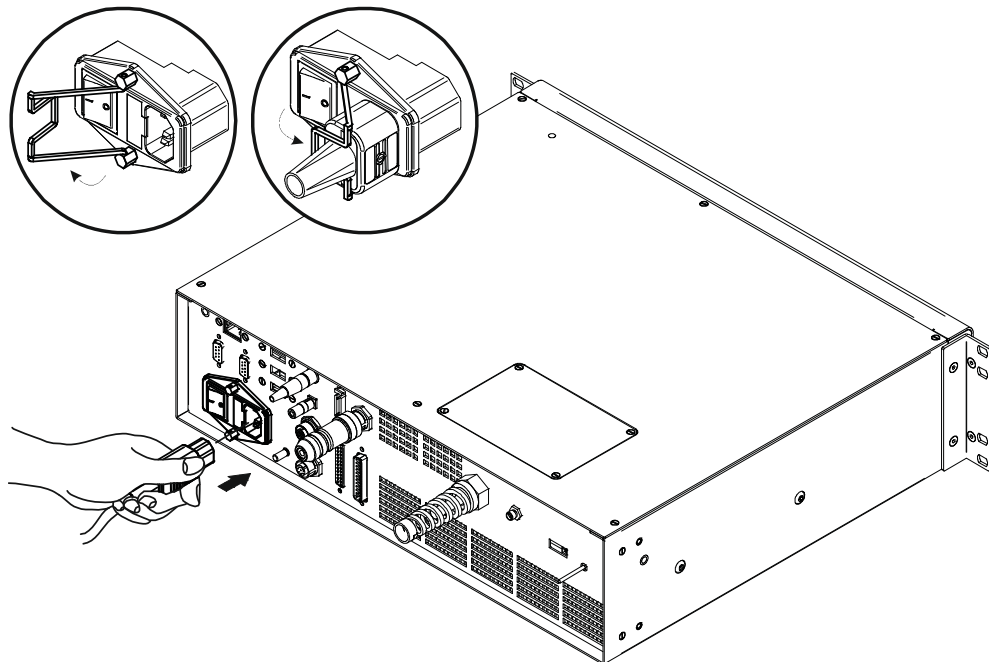

Figure 52: Power Supply cable connection

Connecting the Earth Ground

To ensure high electrical noise immunity it is strongly recommended to connect the chassis to suitable earth ground.

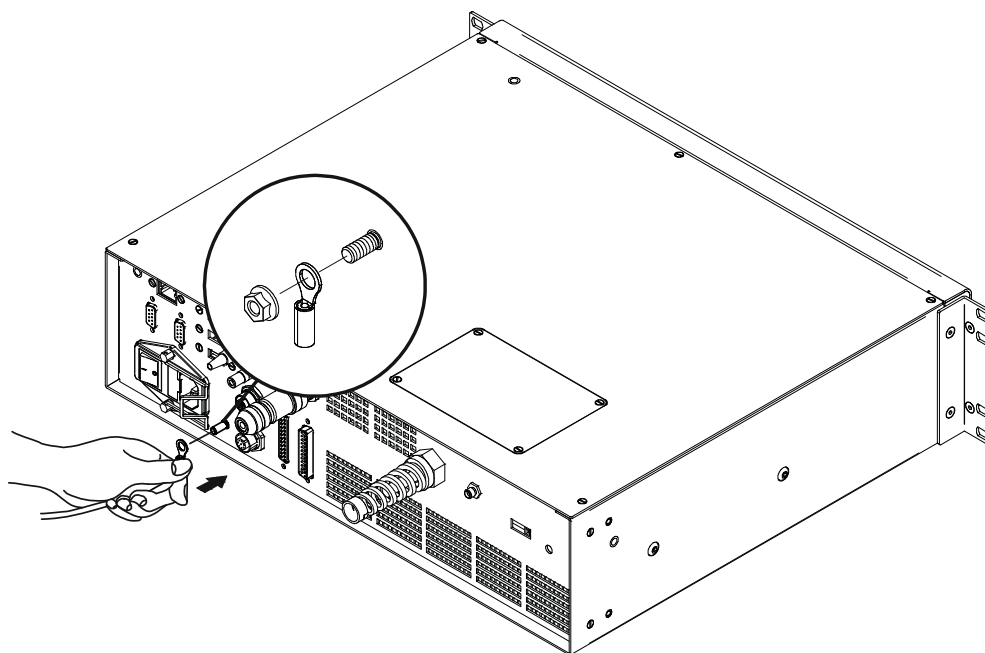

Figure 53: Connecting the Earth Ground

Connecting resonator power supply cable

Connect the AC power supply to the resonator.

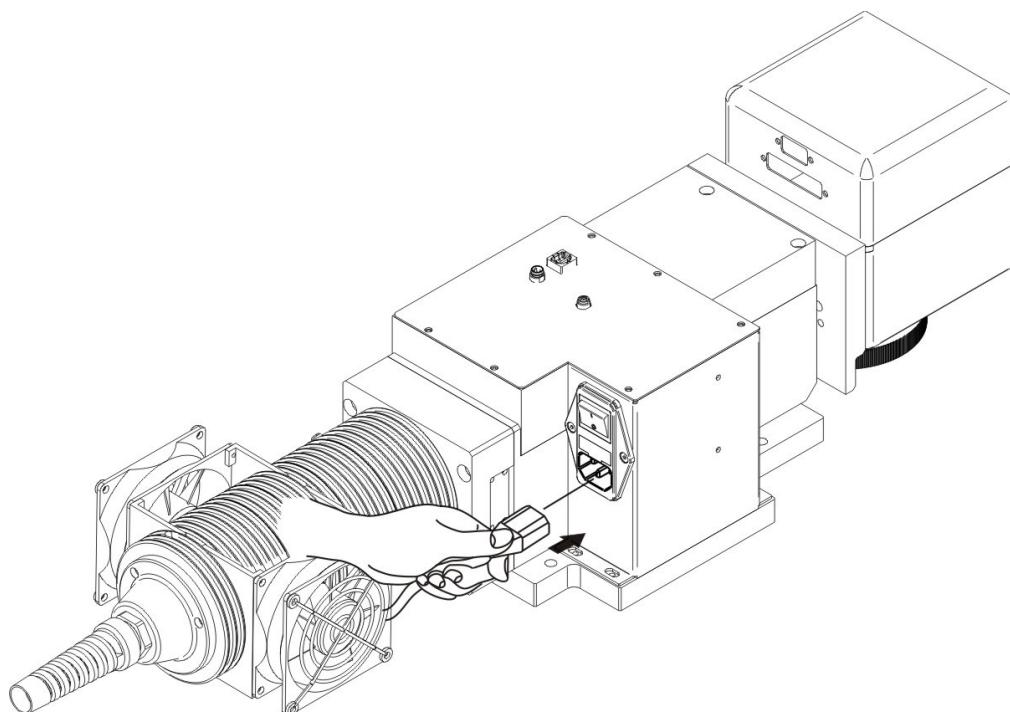

Figure 54: Connecting the power supply to resonator

Local Mode Control connections

To use the laser marker in “Local Mode Control” it is necessary to install a mouse, keyboard and monitor. Connect the monitor and input devices to laser marker as shown below:

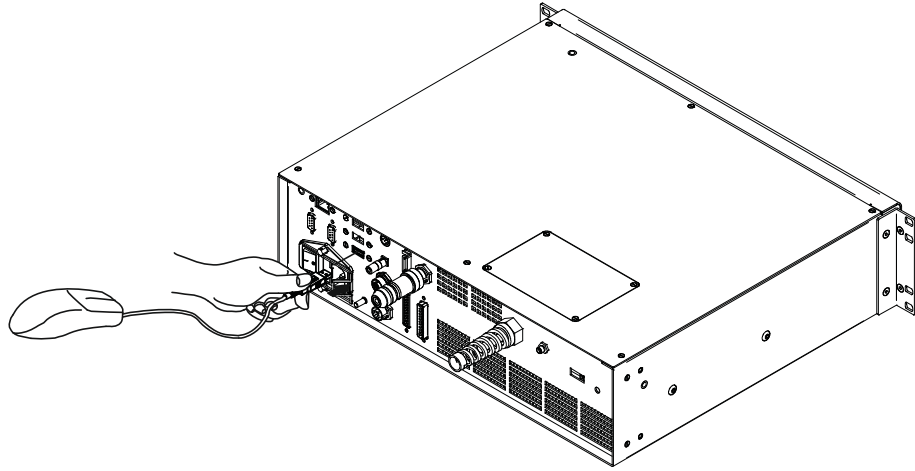

Figure 55: Connecting the mouse

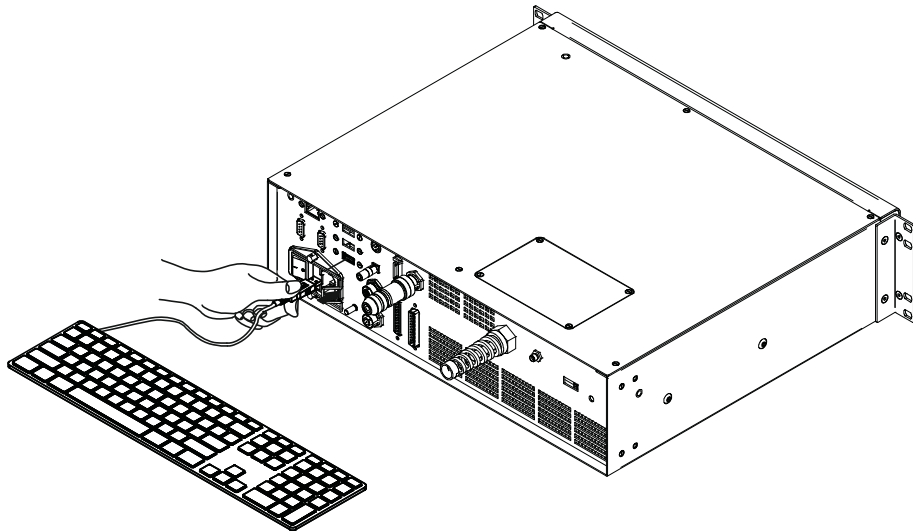

Figure 56: Connecting the keyboard

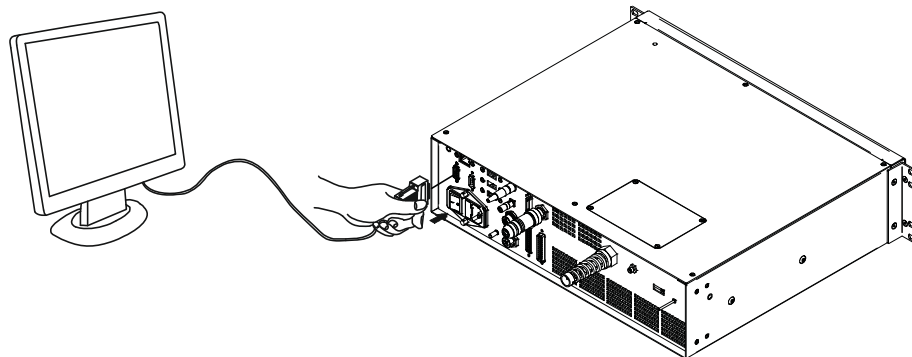

Figure 57: Connecting the monitor



NOTE: Minimum monitor resolution 800 x 600 (VGA standard).

Remote Mode Control connection

To use the laser marker in "Remote Mode Control" it is necessary to connect a network cable:

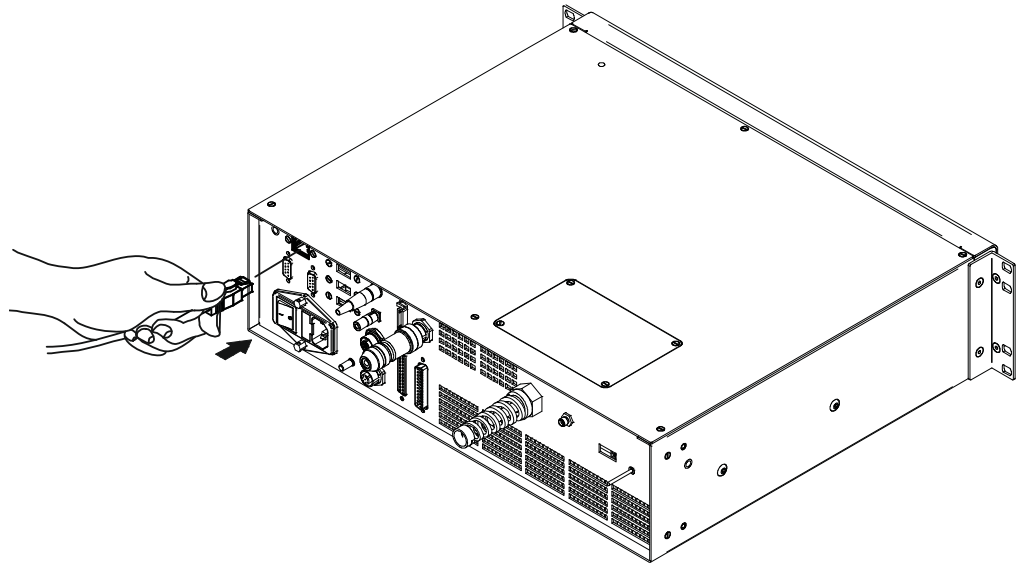

Figure 58: Connecting LAN port



NOTE: The LAN port is configured by default with a fixed IP Address and Subnet Mask:

- Default IP address: 192.168.1.10
- Default Subnet Mask: 255.255.255.0

See "Change the LAN configuration and IP address" on page 73 in order to change LAN configuration.



NOTE: Ethernet TCP/IP 10, 100 Mbit.

F-Theta scan lens protection cap removal

Remove the F-Theta scan lens protection cap before marking operation:

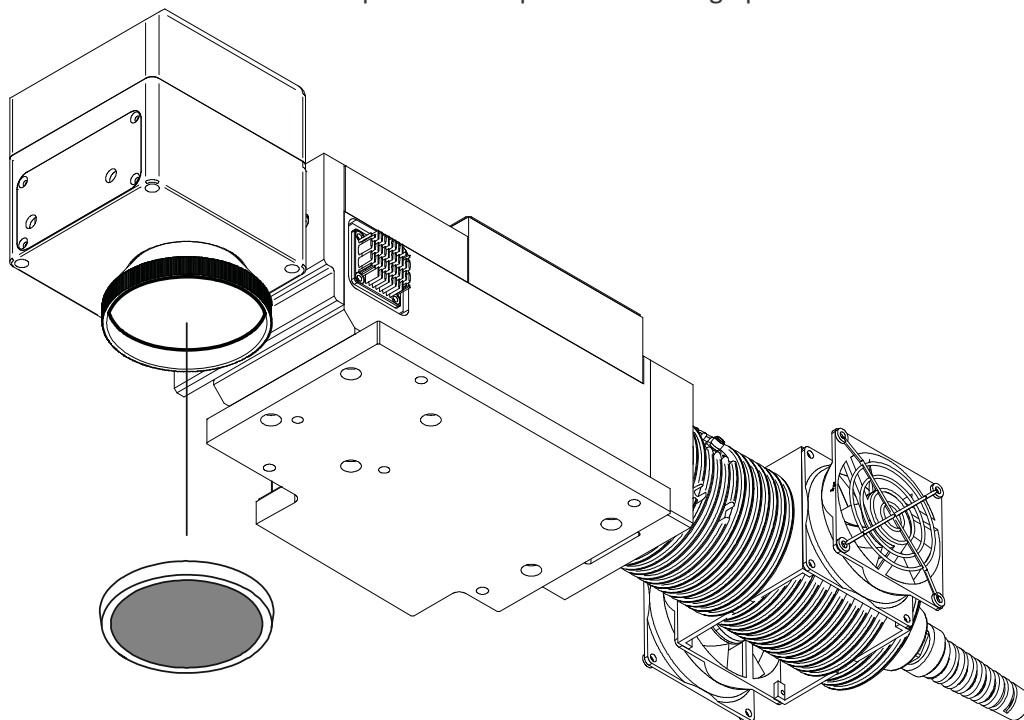

Figure 59: F-Theta scan lens protection cap removal



CAUTION: Marking with the lens protection cap in place could result in damage to the laser marker.

CHAPTER 5

USE AND OPERATION

Before turning on the laser marker, be sure that the laser marker is connected as previously described. Check the presence of:

- Voltage power supply connection
- Interlock connection
- Command Box connection



WARNING: Do not use the Interlock Muting Device for external devices, since this will result in loss of the safety function of the machine to which this product is installed.

Do not use the Interlock Muting Device except for maintenance on this product.



WARNING: It is the customer's responsibility to provide a correct integration of the safety signals according to applicable regulations.



WARNING: If the Command Box Muting Device provided is connected, the laser marker *ENABLE* is bypassed.

TURNING ON SEQUENCE

The laser marker states can be controlled by:

- **Key and Enable Selectors**
- **X1 - Command Box connector**

Preliminary operation

Turn ON the switch on resonator. Wait about 20 minutes before proceeding to the next step. This waiting time is necessary for the correct warm-up and performance stabilization of the resonator:

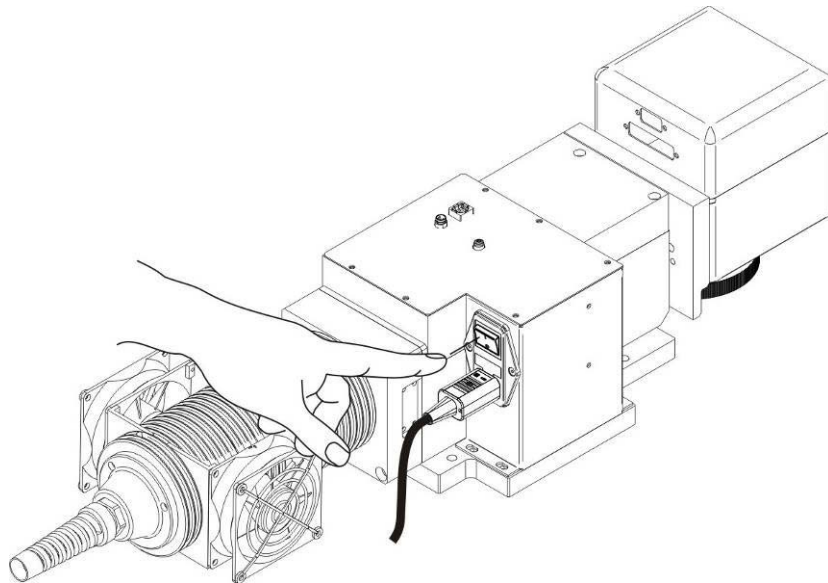

NOTE: The warm up time is about 20 minutes using 220V AC power supply. Using 110V AC the warm up time is longer.

Sequence using Key and Enable Selectors



CAUTION: Controlling the laser marker states using the Key and Enable Selectors on the control rack front panel requires that the input signals of the command box connector X1.12 (*EXT_KEY*), X1.8 (*EXT_ENABLE_A*) and X1.2 (*EXT_ENABLE_B*) are set to fixed HIGH level.

1. **Turn ON** the main power supply switch in the back panel of the control rack. The laser marker turn on and goes in booting-up state:

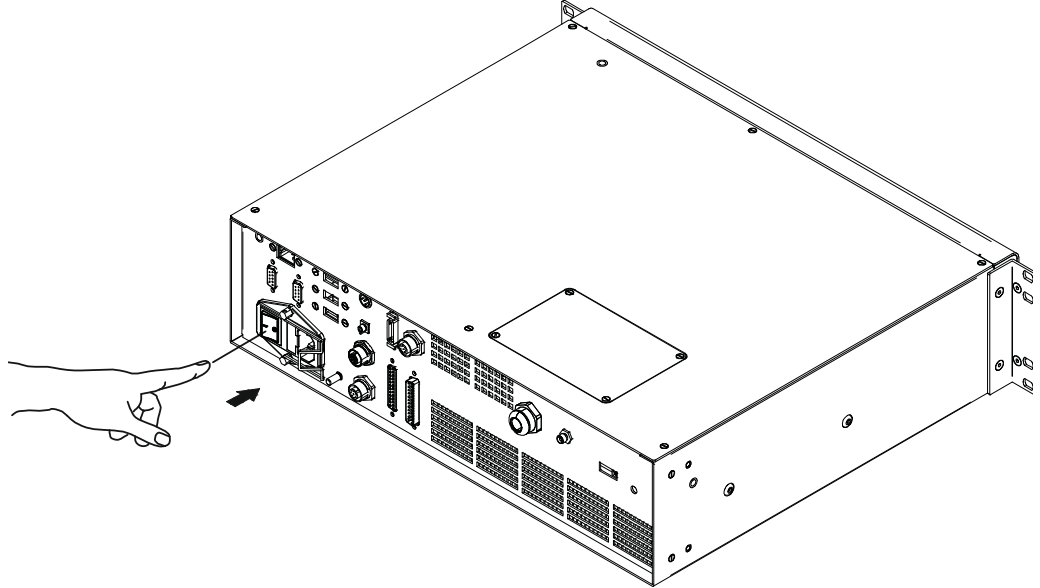

Figure 60: Power on

During booting-up state, the status LED on the control rack blink green.

Wait until booting-up finish: the status LED on the control rack is steady green. The laser marker is in *WAIT FOR START* state.

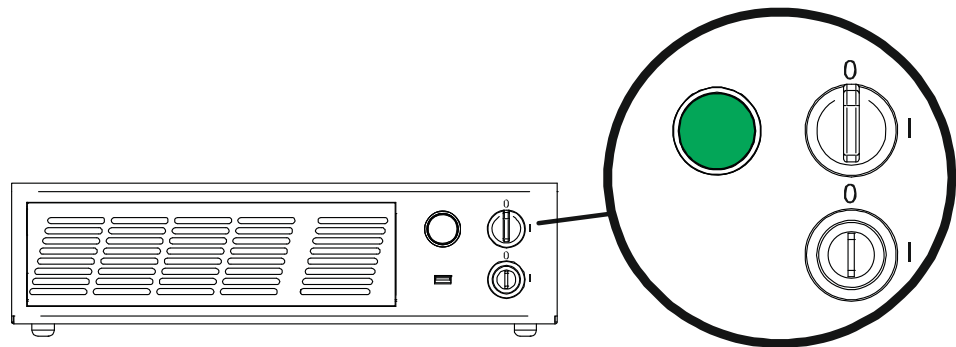

Figure 61: Wait for start state

2. activate the **KEY** selector, by rotating it clockwise:

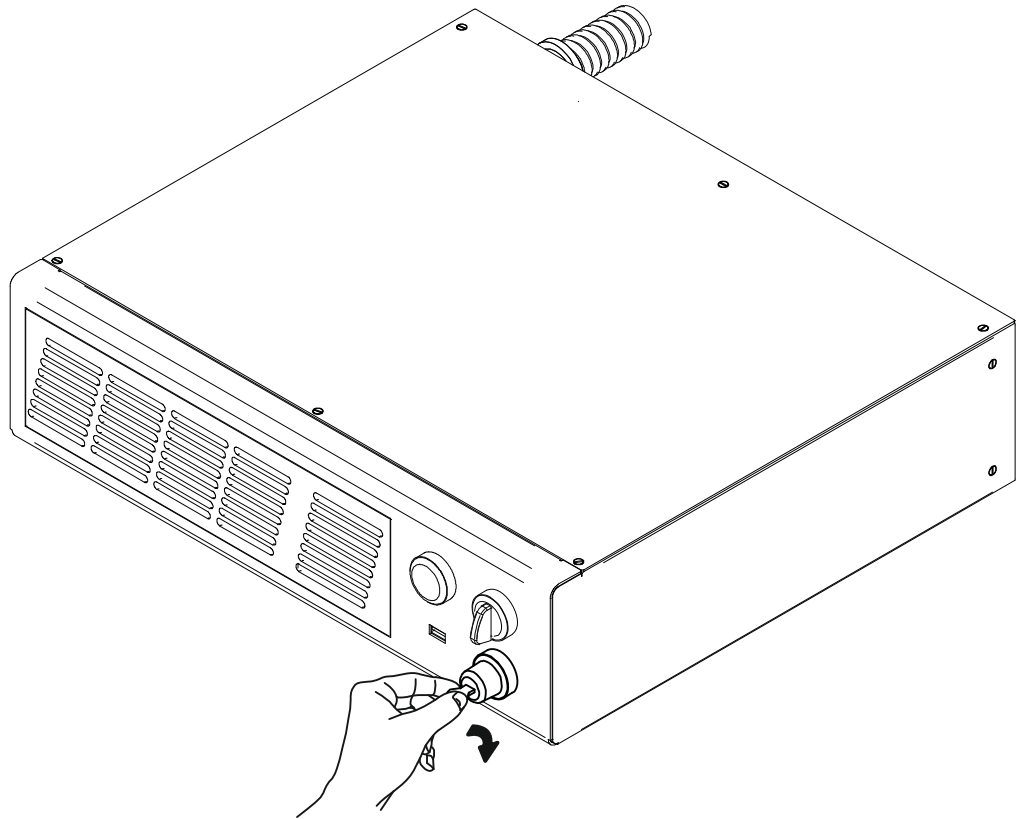

Figure 62: Enable command KEY

The status LED on the rack will be blinking orange for about 30 seconds (laser source warm-up).

Wait until laser source warm-up finishes. The status LED on the rack will be steady orange. The laser marker is in *STANDBY SHUTTER CLOSED* state.

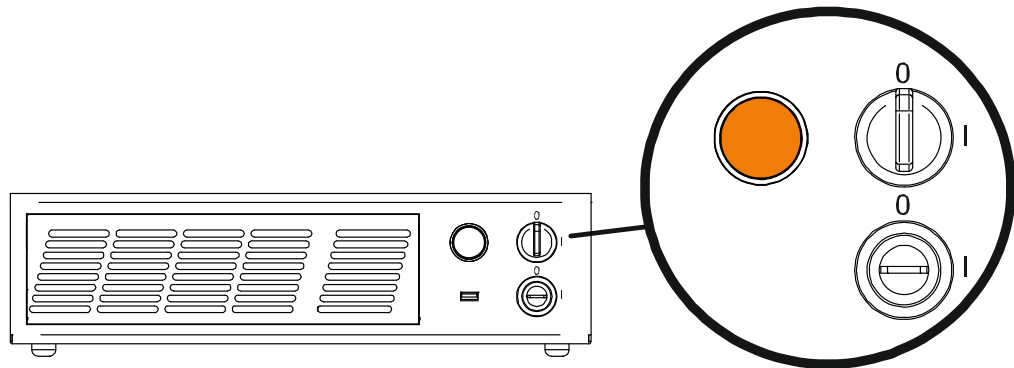

Figure 63: Standby Shutter closed state

- activate the **ENABLE** selector by rotating it clockwise:

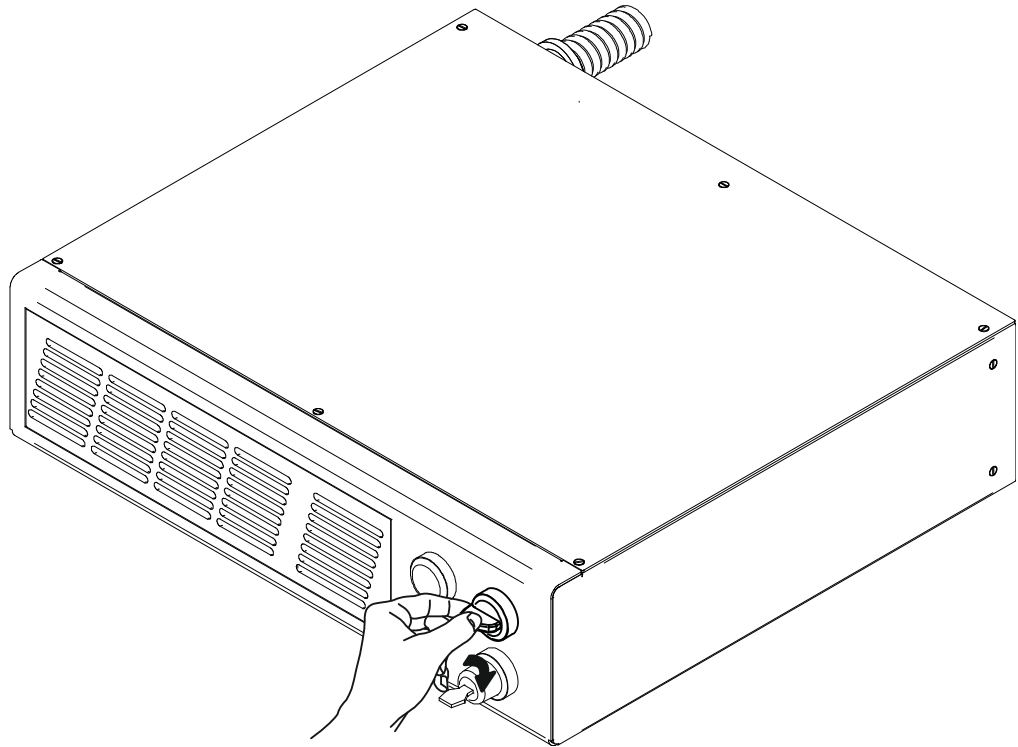

Figure 64: Enable command ENABLE

The laser marker is in *READY* state. The status LED on the rack will turn red.

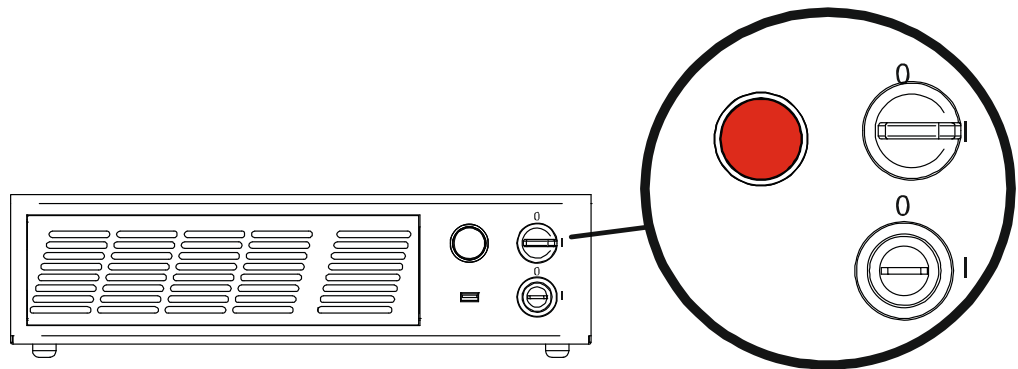

Figure 65: Ready state

Sequence Using X1 - Command Box



CAUTION: Controlling the laser marker states using the X1 - Command Box connector on the control rack back panel requires that the *Key and Enable Selectors* are set to fixed position 1.

Turn **ON** the main power supply switch in the back panel of the control rack. The laser marker turns on and goes in booting-up state. During booting up state, the status LED on the control rack blink green.

Wait until booting-up has ended: the status LED on the control rack is steady green. The laser marker is in *WAIT FOR START* state.

STATE	X1 - COMMAND BOX INPUT STATE		KEY-ENABLE SELECTOR	STATUS LED
WAIT FOR START	EXT_KEY EXT_ENABLE_A EXT_ENABLE_B	LOW LOW LOW		 Steady

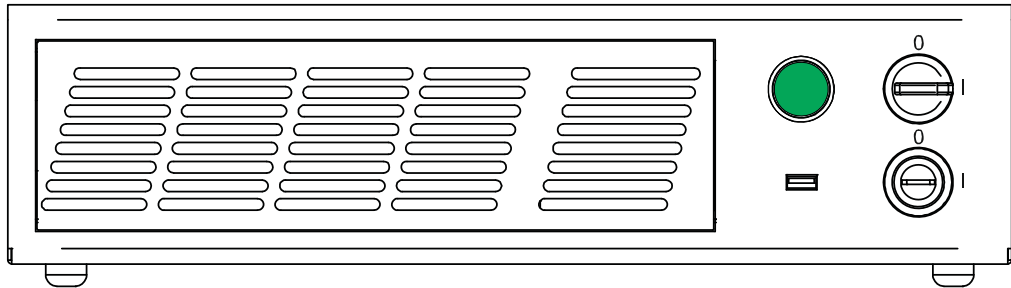

Figure 66: Wait for start state

Set the X1 - Command Box input signals as in the table below:

STATE	X1 - COMMAND BOX INPUT STATE		KEY-ENABLE SELECTOR	STATUS LED
STANDBY SHUTTER CLOSED	EXT_KEY EXT_ENABLE_A EXT_ENABLE_B	HIGH LOW LOW		 Steady

The status LED on the rack will be blinking orange for about 30 seconds (laser source warm-up).

Wait until laser source warm-up finishes. The status LED on the rack will be steady orange. The laser marker is in *STANDBY SHUTTER CLOSED* state.

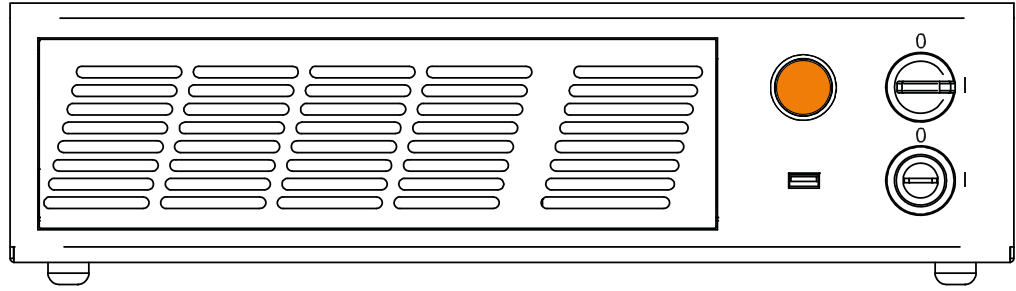
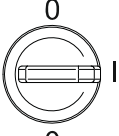
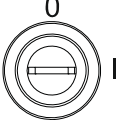



Figure 67: Standby Shutter closed state

Set the *X1 - Command Box* input signals as in the table below:

STATE	X1 - COMMAND BOX INPUT STATE		KEY-ENABLE SELECTOR	STATUS LED
READY	EXT_KEY	HIGH	 	 Steady

The status LED on the control rack will turn red. The laser marker is in *READY* state.

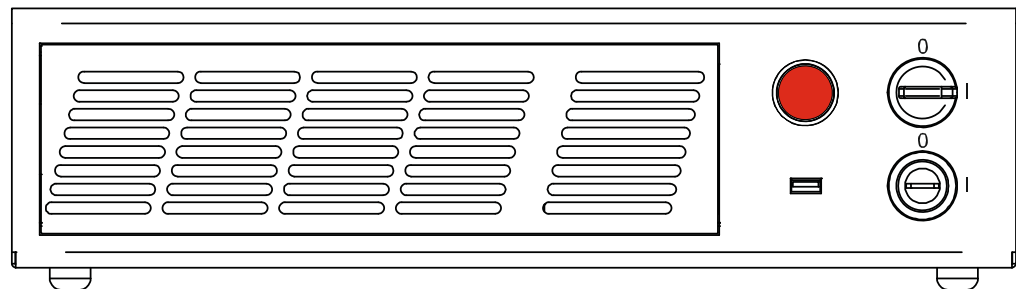

Figure 68: Ready state

CHAPTER 6

CUSTOMIZE THE LASER MARKER SOFTWARE

SYSTEM PROTECTION

The System Protection enhances the security of the system against disk corruption that might be caused by unexpected system shutdowns or malware attacks and protects the **C:\ drive** from unwanted changes.

When the System Protection is enabled, any change or deletion on the C:\ drive will be restored after system reboot, otherwise when the System Protection is disabled any modification will be stored on the disk and it will persist after reboot.

System Protection Tool

The System Protection tool shows the status of the System Protection and is visible on the tray-bar icon in the lower- right corner of the screen.

A notification popup message that shows the status of System Protection is still visible on the screen for a few seconds after system startup.

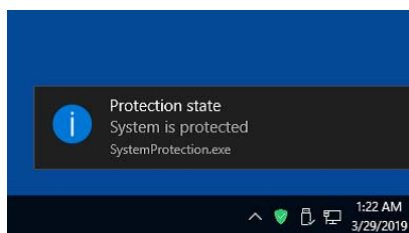

The tray-bar icon color represents the protection state:

- **Red:** the system protection is **disabled**
- **Green:** the system protection is **enabled**
- **Yellow:** the system **must be rebooted** to apply the new settings

How to use the System Protection tool

The System Protection tool GUI can be opened:

- By clicking on the notification popup
- By right-clicking the tray-bar icon then, “Configure”
- Double-clicking the tray-bar icon
- From *Start Menu\Datalogic\System Protection*

Enable the system protection



NOTE: When the System Protection is enabled any change or deletion on the C:\ drive will be restored after system reboot.

- Open the System Protection tool GUI
- Click the **ENABLE** button

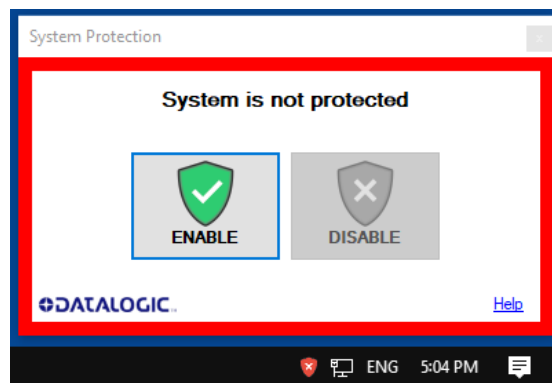

- A message advise the User to confirm the new setting. Press **YES** to enable System Protection

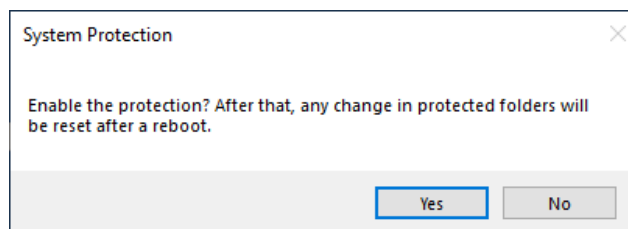

- A message advise the User that the system will be rebooted. Press **YES** to continue

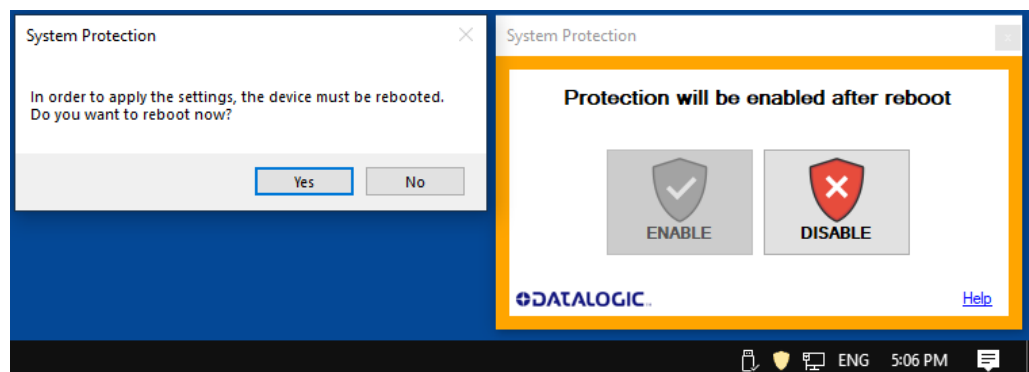

- Wait for system reboot



CAUTION: DO NOT turn OFF or UNPLUG the system while Windows® is shutting down.

- Check if the Tray-bar icon color is **GREEN** (protection enabled)

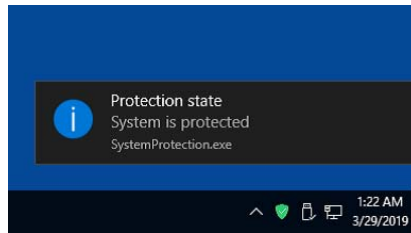

Disable the system protection



CAUTION: When the System Protection is disabled the system is not protected against disk corruption or malware attacks. Disable the protection only for the time necessary to make disk changes.

- Open the System Protection tool GUI
- Click the **DISABLE** button

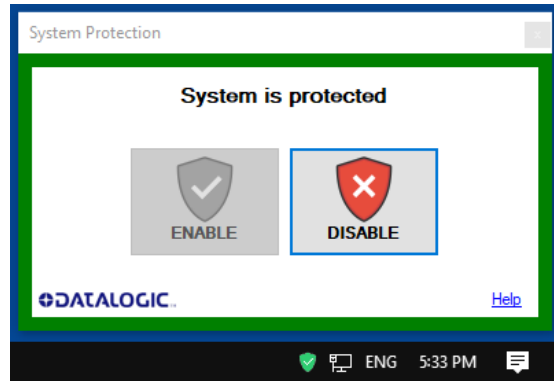

- A message advise the User to confirm the new setting. Press **YES** to disable System Protection

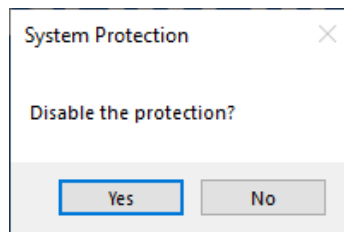

- A message advise the User that the system will be rebooted. Press **YES** to continue

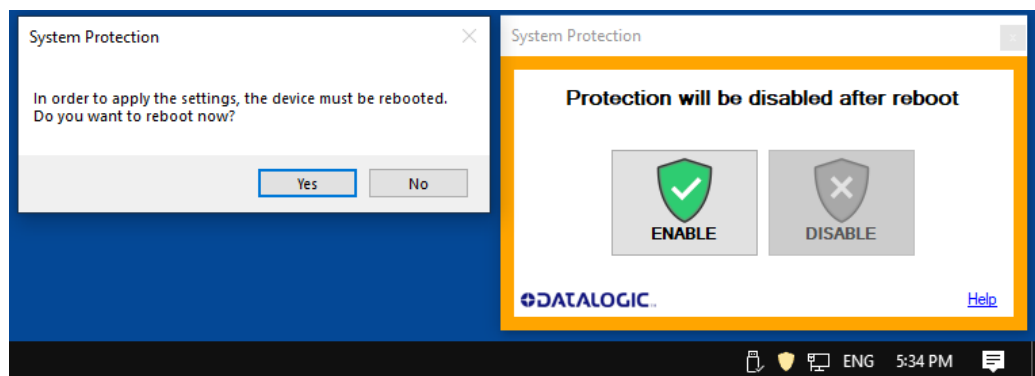

- Wait for system reboot



CAUTION: DO NOT turn OFF or UNPLUG the system while Windows® is shutting down.

- Check if the Tray-bar icon color is **RED** (protection disabled)

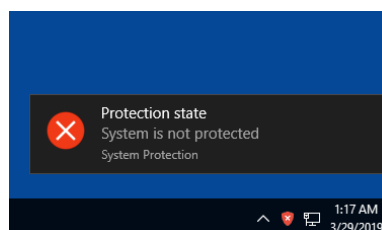

CHANGE O.S. LANGUAGE AND KEYBOARD LAYOUT

The laser marker allows you to customize the operating system changing the language used in menus, dialogs and languages you can use to enter text and keyboard layout.

The following languages are pre-installed in the system: Chinese (PRC), Chinese (Taiwan), English (United States), French (France), German (Germany), Italian (Italy), Japanese (Japan), Korean (Korea), Spanish (Spain).



NOTE: In order to perform this setting it is necessary to connect mouse, keyboard and monitor to the laser marker (see “Local Mode Control connections” on page 56).

1. Disable system protection (see “Disable the system protection” on page 69)



CAUTION: When the System Protection is disabled the system is not protected against disk corruption or malware attacks. Disable the protection only for the time necessary to make disk changes.

2. Wait for the operating system to **restart**
3. Check that the System Protection is **disabled** (red icon):

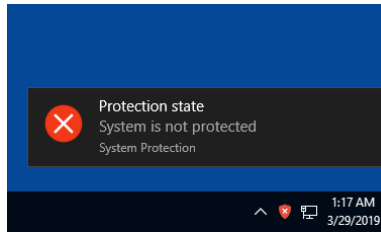

4. Click the **Search icon** and type “**language**”
5. Click on **Language settings**

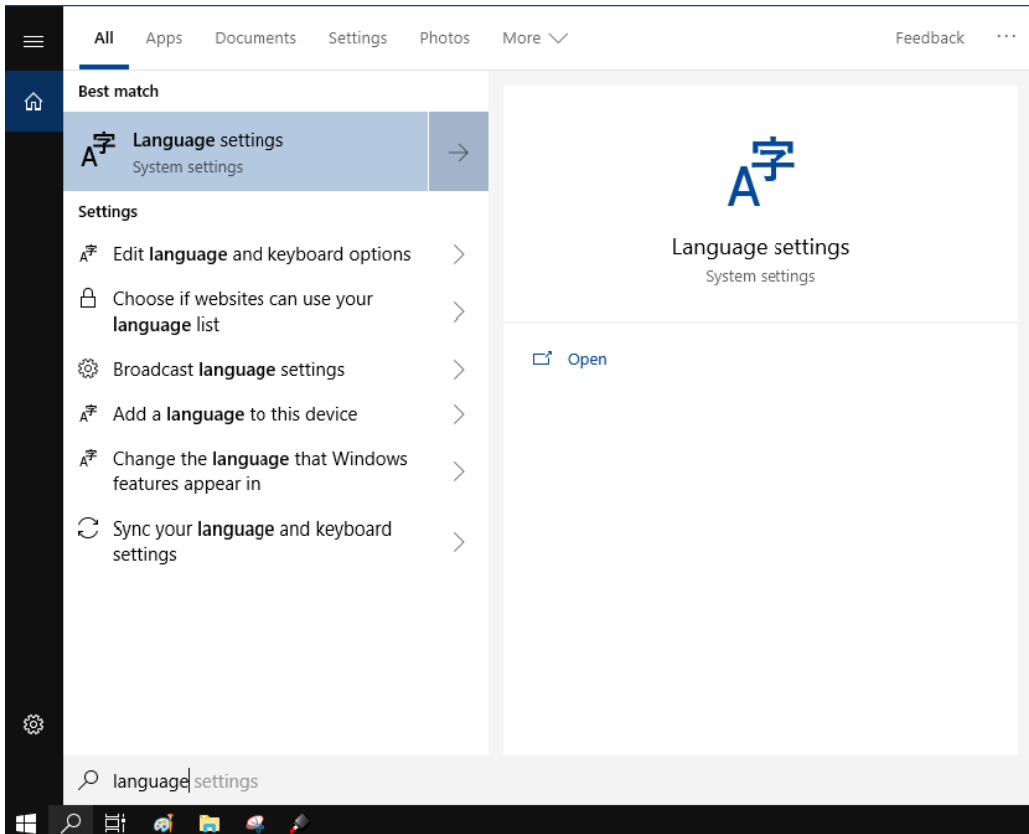

6. Select the Windows display language:

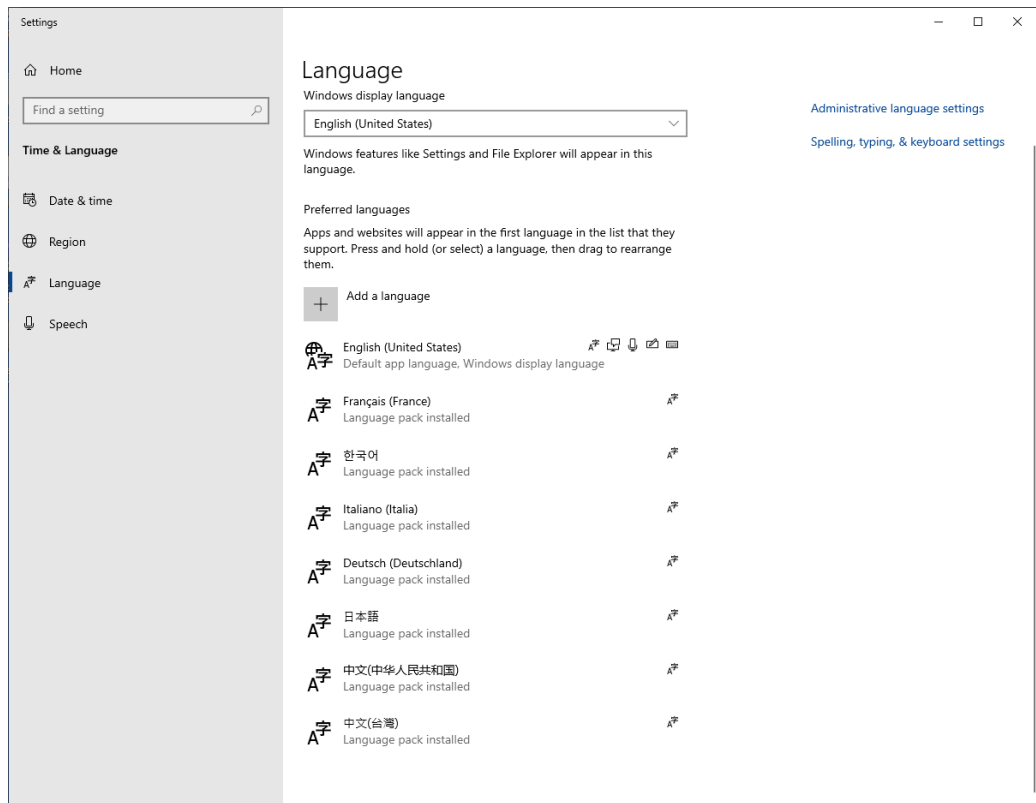
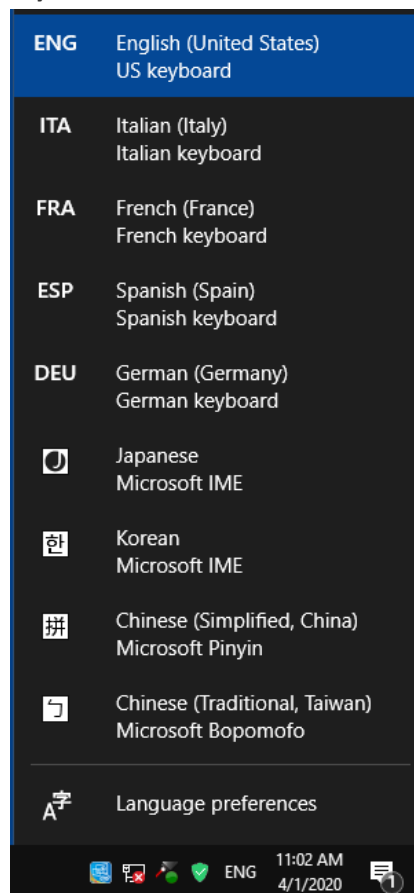
7. Click on the **Input Indicator** icon in the taskbar8. Select the **keyboard layout** from the list:

9. Close all the open windows

10. Enable system protection (see “Enable the system protection” on page 67)



CAUTION: When the System Protection is disabled the system is not protected against disk corruption or malware attacks.

11. Wait for the operating system to **restart**
12. Check that the System protection is **enabled** (green icon):

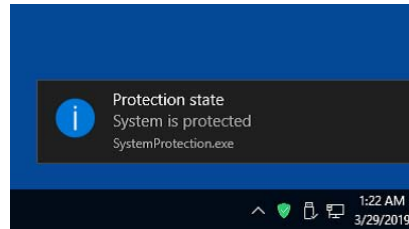

CHANGE THE LAN CONFIGURATION AND IP ADDRESS

The operating system allows you to change the LAN configuration and IP address.



NOTE: In order to perform this setting it is necessary to connect mouse, keyboard and monitor to the laser marker (see “Local Mode Control connections” on page 56).

1. Disable system protection (see “Disable the system protection” on page 69)



CAUTION: When the System Protection is disabled the system is not protected against disk corruption or malware attacks. Disable the protection only for the time necessary to make disk changes.

2. Wait for the operating system to **restart**
3. Check that the System protection is **disabled** (red icon):

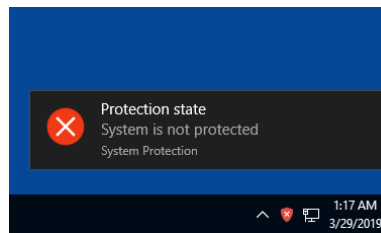

4. Click the **Search icon** and type “Ethernet”
5. Click on **Ethernet settings**

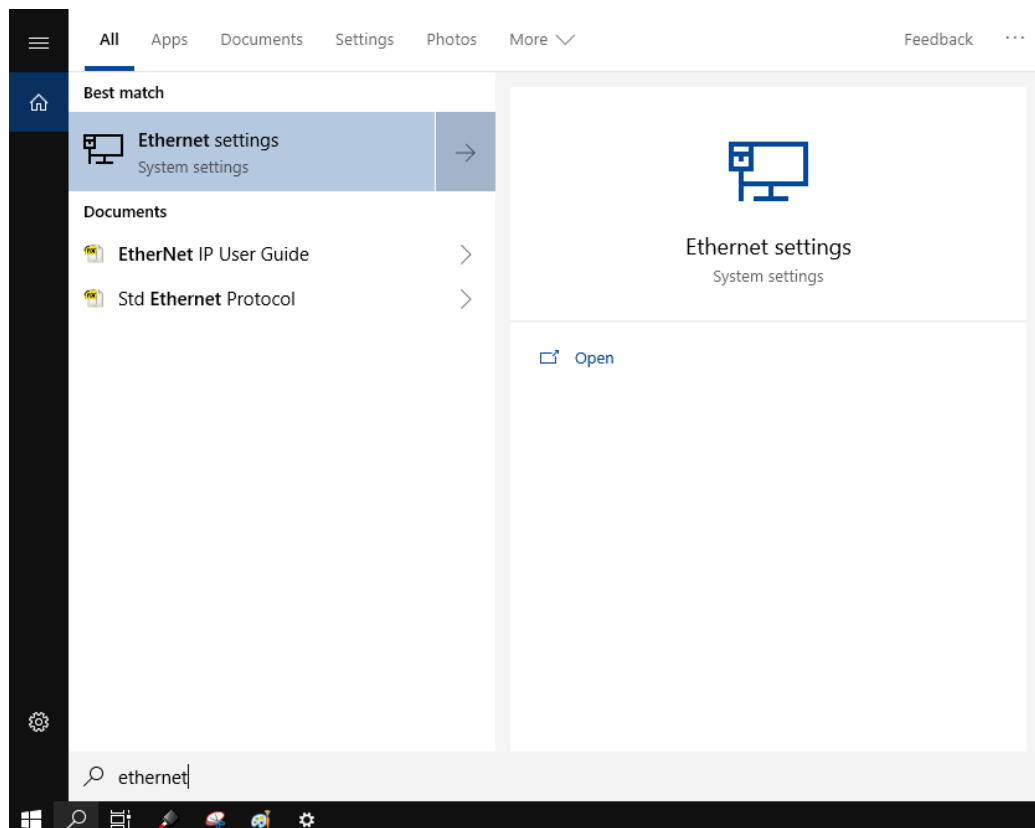

6. Click on **Change adapter options**

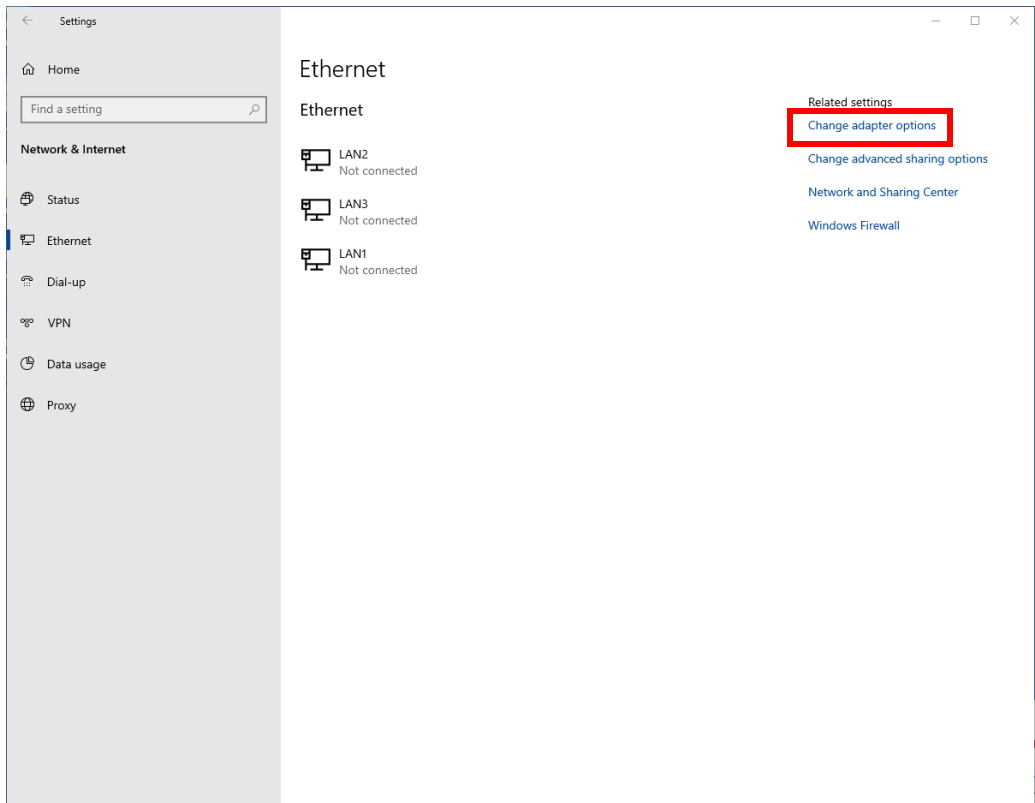

7. In the Network Connections window double click on the desired Network icon:

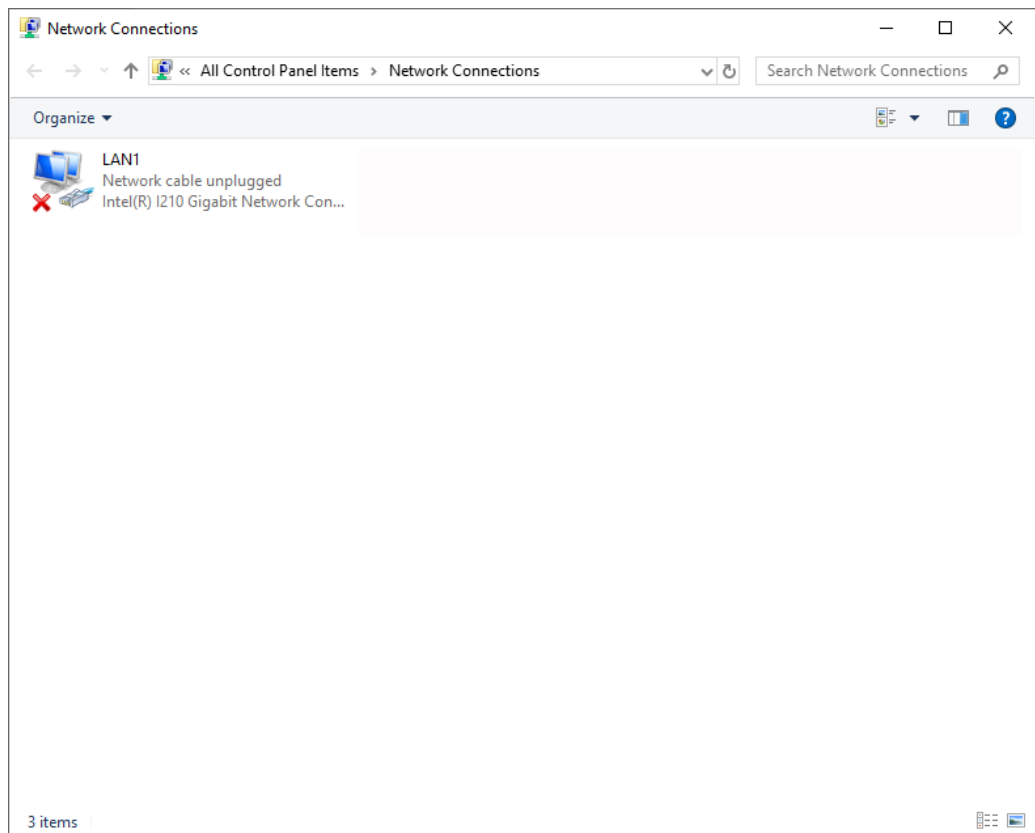

- In the Network Properties window double click on **Internet Protocol Version 4 (TCP/IPv4)** and edit the IP address and/or subnet mask.

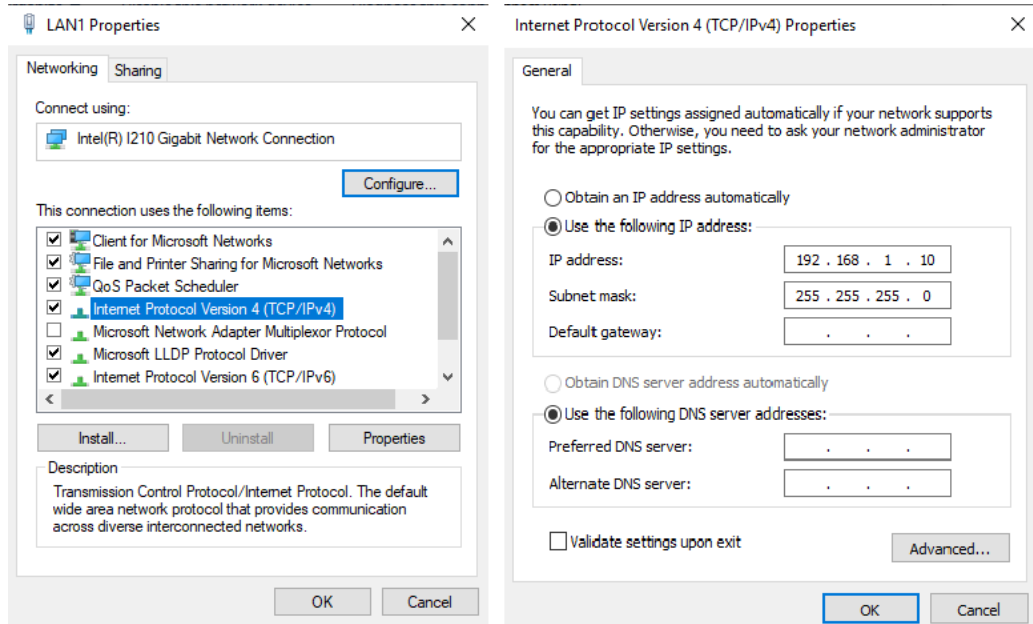

- Close all the open windows
- Enable system protection (see “Enable the system protection” on page 67)



CAUTION: When the System Protection is disabled the system is not protected against disk corruption or malware attacks.

- Wait for the operating system to **restart**
- Check that the System protection is **enabled** (green icon):

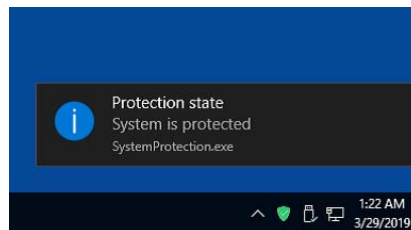

CHANGE THE VIDEO SETTING

The operating system allows you to change the Video setting.



NOTE: In order to perform this setting it is necessary to connect mouse, keyboard and monitor to the laser marker (see “Local Mode Control connections” on page 56).

1. Disable system protection (see “Disable the system protection” on page 69)



CAUTION: When the System Protection is disabled the system is not protected against disk corruption or malware attacks. Disable the protection only for the time necessary to make disk changes.

2. Wait for the operating system to **restart**
3. Check that the System protection is **disabled** (red icon):

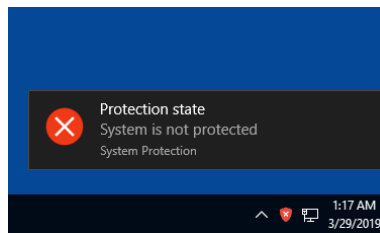

4. Click the **Search icon** and type “display”
5. Click on **Display settings**

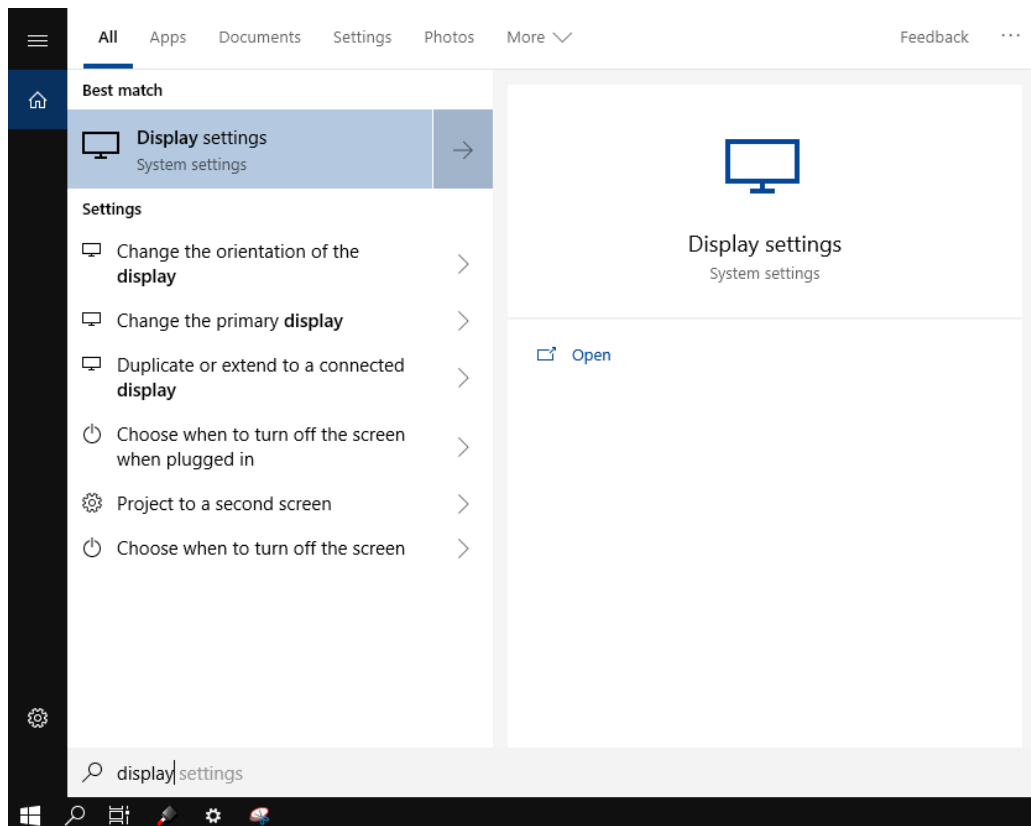

6. Change the Display settings

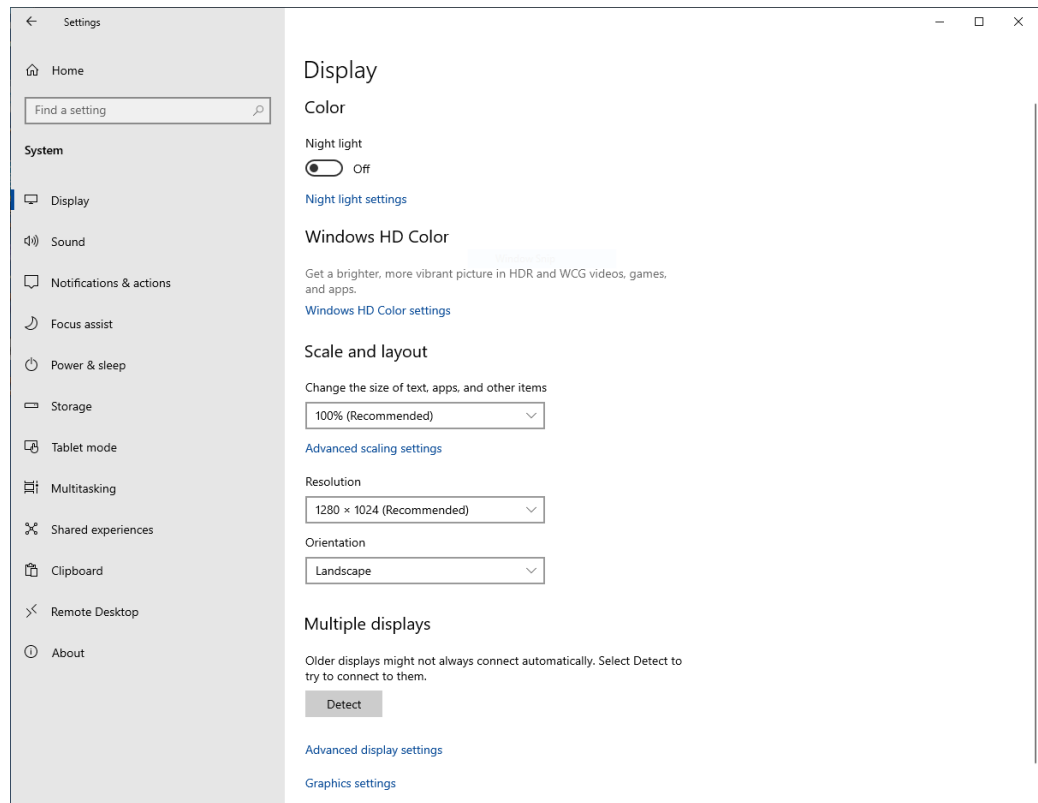

7. Close all the open windows

8. Enable system protection (see “Enable the system protection” on page 67)



CAUTION: When the System Protection is disabled the system is not protected against disk corruption or malware attacks.

9. Wait for the operating system to **restart**

10. Check that the System protection is **enabled** (green icon):

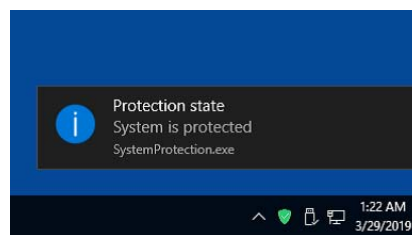

REMOTE DESKTOP CONNECTION

To connect the laser marker to a remote Windows® based computer, follow these steps:

1. Turn on the laser marker
2. Make sure that both laser marker and remote computer are connected to the LAN
3. Click **Start > All Programs > Accessories**, and then click **Remote Desktop Connection**
4. Click **Options**
5. In the Computer list, type the host name or the IP address of the computer to which you want to connect
6. Type the user name, password, and domain (if applicable) of an account to which you have allowed remote access into the corresponding boxes, and then click **Connect**



7. In the **Log On to Windows®** dialog box that appears, type the password of the account with remote access privileges into the Password box:

User name: **DLA**

Password: **dla**



8. In the **Log on to list**, if applicable, select the domain or remote computer that you want, and then click **OK**.
The remote desktop is displayed in a window on the desktop. The remote computer is locked during this session
9. To disconnect the session, click the **Close** button in the session window, and then click **OK** when you are prompted to disconnect the Windows® session.

CHAPTER 7

ACCESSORIES

The accessories listed here below are described for information purposes only, and are not necessarily included in the packaging. The minimum contents of the packaging include the main hardware, cables and keys. For additional information, please see "Contents of the packaging" on page 10.

CONTROL BOX

This accessory is used to control the laser marker through the Control Box interface.

The Control Box allows to perform the following functions:

- Changing laser marker state
- Starting and Stopping the marking process
- Showing the marking process state
- Showing the system error state

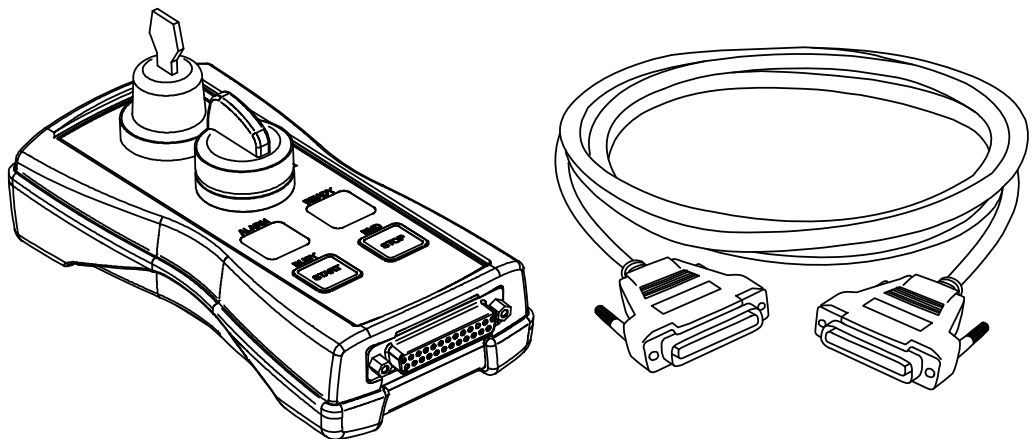

Figure 69: Control Box (ordering no: 985330031)



NOTE: See "X1 - Command Box (laser control)" on page 29 for detailed control signal description.

REMOTE START FOOT SWITCH

This accessory is used to provide the *START_MARKING* signal to the laser marker when the pedal is pressed by the operator.

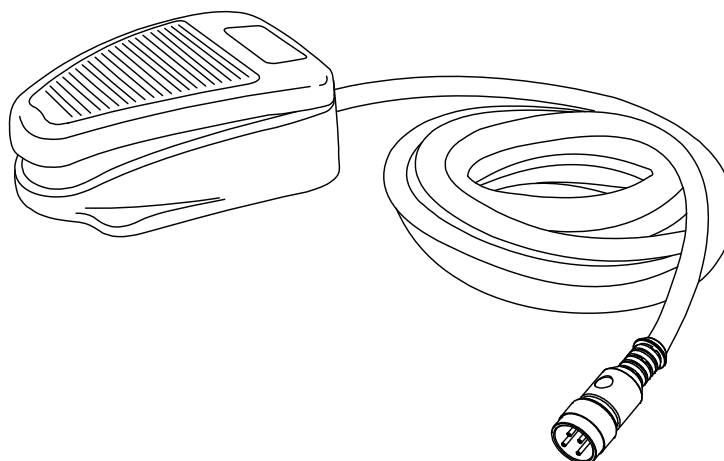

Figure 70: Remote Start Foot Switch (ordering no: 985350035)



NOTE: Refer to Remote Start Foot Switch instruction manual for more information.

I/O INTERFACE

Dedicated to on-site quick and easy termination, PLC interfacing, System Test, I/O troubleshooting, etc. The DB25 Pass-through Command Box connector allows the integrator to use the interface as a I/O test tool on previously installed products.

- I/O Monitoring LED
- Easy assembly thanks to screw down termination
- Dry contact outputs
- Dry contact inputs
- DIN rail mounting enclosure

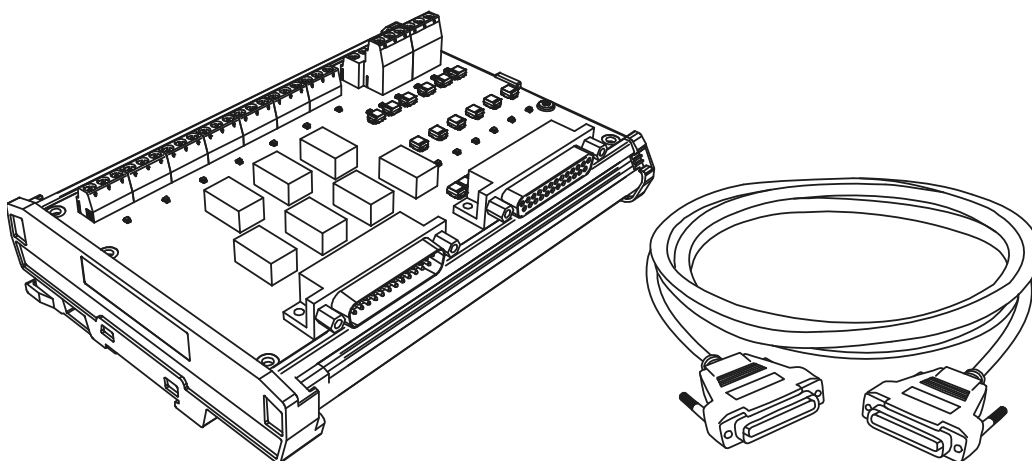

Figure 71: I/O interface (ordering no: 985330032)



NOTE: Refer to I/O Interface instruction manual for more information.

MARVIS™ ADD-ON

MARVIS™ is the most advanced MARK and VALIDATE solution for traceability. The innovative Code Quality Training dramatically simplifies setup in a real production environment. The MARVIS™ Add-on for Vlase includes:

- MATRIX™ 300N reader
- Power & signals cable
- Ethernet cable
- Power Supply
- MARVIS™ license

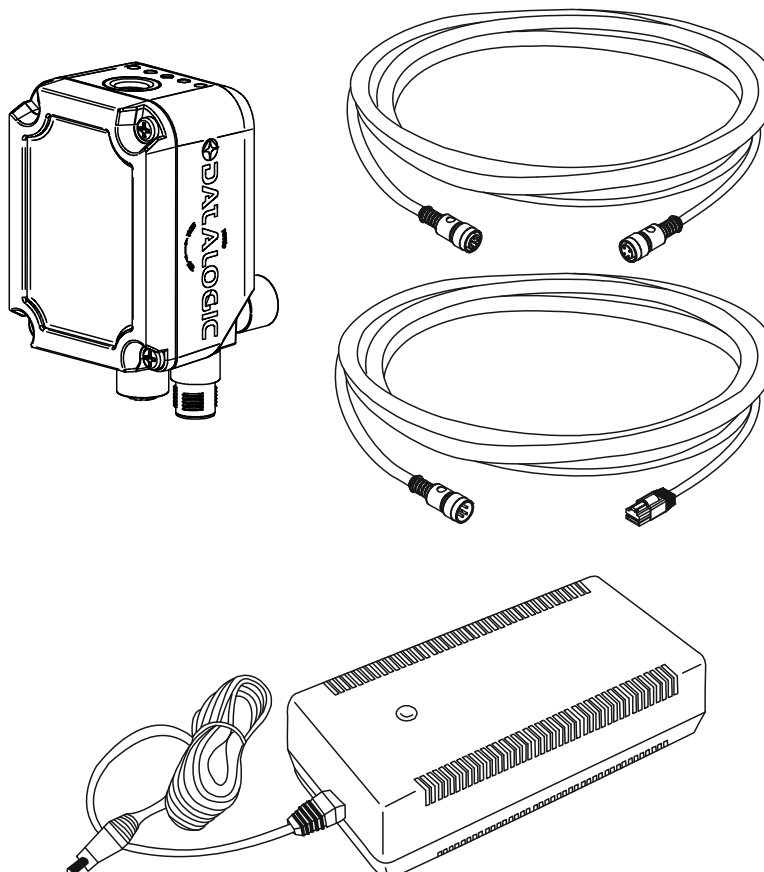

Figure 72: MARVIS™ Add-on for Vlase™ (ordering no: 937600122)



NOTE: Refer to MARVIS™ Application Note for more information.

DB25-TO-FREE LEADS CABLE

This accessory allows an easier integration of the laser marker: the Command Box connector signals are all available on the free leads side of the cable, labeled with cable tags.

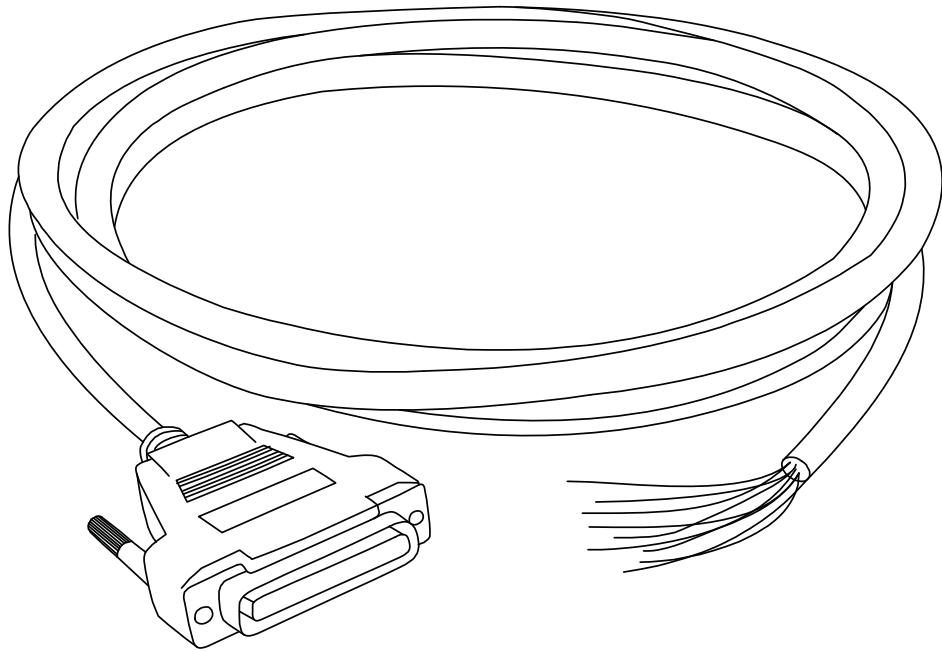

Figure 73: DB25-to-free leads cable (ordering no. 985350032)

FUME EXTRACTOR

This accessory is suitable for collecting and filtering dry and non combustible types of dust contained in non explosive air mixtures produced during laser marking.

MODEL	ELECTRICAL DATA	HOSE / NOZZLE
985340038 - FUME EXTRACTOR BASIC 230VAC	230 VAC, 1 phase, @ 50 Hz (EU)	50-50 mm hose, length 4 m. 50 mm nozzle assembly
985340040 - FUME EXTRACTOR BASIC 115VAC	115 VAC, 1 phase, @ 60 Hz (US)	50-50 mm hose, length 4 m. 50 mm nozzle assembly
985340039 - FUME EXTRACTOR PRO 90-257VAC	90 - 257 VAC, 1 phase, @ 50-60 Hz	75-50 mm hose, length 4 m. 50 mm nozzle assembly

CHAPTER 8

TECHNICAL SUPPORT

SEALS

The laser marker has seals in some areas. The seals must not be broken or removed for any reason. The sealed parts may be opened only and exclusively by Datalogic. Breaking these seals voids the warranty on the entire laser marker.



CAUTION: If customer breaks or removes the seals placed by Datalogic on the laser marker the warranty will immediately become “null and void”.



CAUTION: Datalogic shall not be held liable for any non-conforming use of the laser marker.

It is forbidden to operate the laser marker before the machine where it is integrated has been declared in conformance with applicable statutory Directives.



CAUTION: Only Datalogic authorized personnel, who have been trained and instructed on the electrical and optical risks, is allowed to access the internal parts of the control rack.

Datalogic shall not be held liable for any damage caused by inadequate work from non-authorized personnel.



CAUTION: Only Datalogic authorized personnel, who have been trained and instructed on the electrical and optical risks, is allowed to access the internal parts of the resonator.

Datalogic shall not be held liable for any damage caused by inadequate work from non-authorized personnel.

MAINTENANCE

The ordinary maintenance program of the laser marker includes only simple operations. Some operations consist in a mere “check” of the operating condition.

The maintenance activities must be done in compliance with the legal directives regarding the safety rules during these operations.

The following parts/functions have to be controlled periodically:

COMPONENT	TYPE OPERATION	INTERVALS
F-Theta Scan Lens	Check / Clean	Weekly: wipe gently with a dry cloth (or soaked in high purity isopropyl alcohol) or clean it with dry air blowing
Rack Air filter	Clean / Replace	Every 3 months (according to the environment and frequency of use)

F-Theta scan lens cleaning procedure

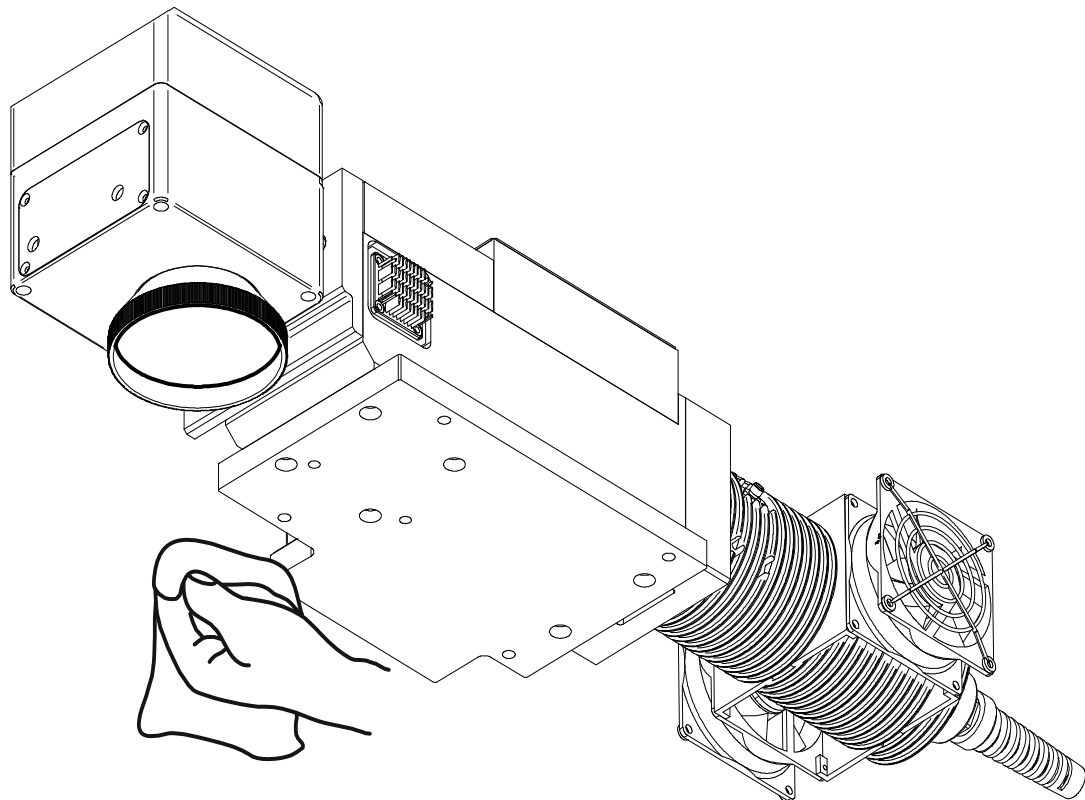

Figure 74: Cleaning F-Theta scan lens



CAUTION: Disconnect AC power cable before starting any maintenance operations.

Air filter cleaning procedure

Procedure:

- Turn off key switch on controller unit
- Disconnect AC power cable
- Unscrew grid panel screws and remove it
- Remove filter

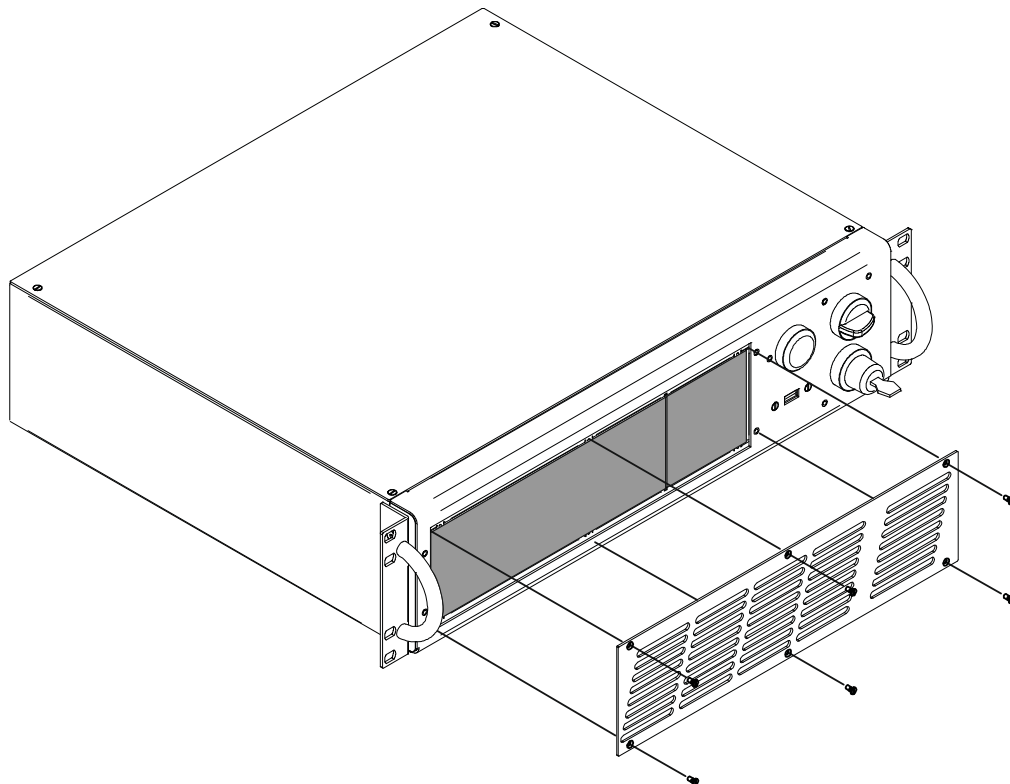

Figure 75: Removal of air filter

- Clean filter with compressed air or with neutral detergent and air-dry it
- Reinstall filter and grid panel



CAUTION: Insert the filter making sure that the surface with the wider meshes is oriented towards the outside.



CAUTION: DO NOT install wet filter!

- If filter cannot be cleaned, replace the filter
- Suitable filters are available as spare parts

TROUBLESHOOTING

If a problem occurs during operation, first check the following troubleshooting. If you cannot fix the problem, contact Datalogic customer service (see “Technical Support” on page vii).

List of warning and error states

STATUS LED	DESCRIPTION	POSSIBLE CAUSE	ACTION	X1 - COMMAND BOX CONNECTOR OUTPUT STATE	
Blinking ORANGE	Warning invalid start sequence	Incorrect turning-on sequence	Set Key and Enable Selectors to “0” and repeat the turning-on sequence. See “Turning on sequence” on page 60	SYSTEM_ALARM POWER_ON ENABLE_OUT	OFF OFF OFF
Blinking RED	System Error	Interlock error	<ul style="list-style-type: none"> - Check <i>Interlock connector</i> signals (see “Interlock” on page 25) - Check <i>Interlock connector</i> presence - Check if <i>X1 - Command Box connector</i> is present - Check <i>X1.10 - CONNCTOR_PRESENCE</i> input signal of the Command Box connector (see “X1 - Command Box (laser control)” on page 29) 	SYSTEM_ALARM POWER_ON ENABLE_OUT	ON OFF OFF
		Temperature error	<ul style="list-style-type: none"> - Check the temperature of the environment where the control rack is placed. The temperature must not exceed the operative limit - Check that the radiofrequency cable (“Connecting Radiofrequency cable” on page 51) is well secured at both ends 		
		Master Oscillator error	Contact <i>Datalogic Technical Support</i>	SYSTEM_ALARM POWER_ON ENABLE_OUT	ON OFF OFF

List of problems related to laser marker states

PROBLEM DESCRIPTION	STATUS LED	POSSIBLE CAUSE	ACTION
Laser marker never goes to WAIT FOR START state	Blinking GREEN	- Lighter™ Suite marking SW corrupted - C:\ or D:\ drive corrupted	Restore the laser marker (see “How to recover the laser marker” on page 122)
Laser marker never goes to STANDBY SHUTTER CLOSED state	Steady GREEN	Key Selector in wrong position	Check the <i>Key Selector</i> is set to 1 (see “Turning on sequence” on page 60)
		EXT_KEY contact is LOW level or disconnected	Check EXT_KEY input signal on the Command Box connector is set to HIGH level (see “X1 - Command Box (laser control)” on page 29)
Laser marker never goes to READY state	Steady ORANGE	Enable Selector in wrong position	Check the <i>Enable Selector</i> is set to 1 (see “Turning on sequence” on page 60)
		EXT_ENABLE_A and/or EXT_ENABLE_B contact are LOW level or disconnected	Check X1.8 (EXT_ENABLE_A) and X1.2 (EXT_ENABLE_B) input signals on the X1 - Command Box connector are set to HIGH level (see “X1 - Command Box (laser control)” on page 29)

List of most common problems

PROBLEM DESCRIPTION	POSSIBLE CAUSE	ACTION
Laser marker doesn't turn ON	Power supply cable disconnected	Check the <i>POWER SUPPLY CABLE</i> connection to the power grid
	Power supply SWITCH set to OFF	Check that the <i>POWER SUPPLY SWITCH</i> is set to ON
	FUSES damaged	Check that <i>FUSES</i> of power supply are not damaged
Impossible to control the marking process using the Command Box control signals	Incorrect integration	Check that the <i>X1 - Command Box</i> control signals are compatible with the external devices used for integration
Bad marking result	F-Theta scan lens is dirty	Clean the <i>F-Theta</i> scan lens. See “F-Theta scan lens cleaning procedure” on page 84
	Incorrect focus distance	Check that the material to be marked is placed at the right working distance. See “Marking Area Specification” on page 23
	Incorrect laser parameters	Check that the laser parameters set in the layout are appropriate for the material to be marked. Contact <i>Datalogic Technical Support</i>
Laser marker doesn't engrave	Incorrect laser marker state	Check the laser marker state is set to READY
	F-Theta lens protection not removed	Check that the <i>F-Theta scan lens protection</i> has been removed
	The optical path is obstructed	Check that the optical path is free

PROBLEM DESCRIPTION	POSSIBLE CAUSE	ACTION
Laser marker doesn't start to engrave using external START_MARKING signal on the X1 - Command Box connector	STOP_MARKING signal is active	Check that the X1.13 (STOP_MARKING) signal on the <i>X1 - Command Box connector</i> is not set to HIGH level
	START_MARKING signal incorrect timing	Check the X1.11 (START_MARKING) signal on the <i>X1 - Command Box connector</i> (see "X1 - Command Box (laser control)" on page 29). HIGH level pulsed signal start the marking process (refer to Lighter™ user's manual "Setting I/O parameters" paragraph to set the signal properties)- Use Lighter™ System Test to check external <i>START_MARKING</i> and <i>STOP_MARKING</i> signals
	Lighter™ is not set in <i>AUTO MODE / WORK MODE</i>	Check that Laser Engine is set in <i>AUTO MODE</i> or that Laser Editor is set in <i>WORK MODE</i>
Laser marker doesn't start to engrave using an external photocell	STOP_MARKING signal is active	Check that the X1.13 (STOP_MARKING) signal on the <i>X1 - Command Box connector</i> is not set to HIGH level
	Incorrect photocell type or incorrect connection	Check that the photocell is compatible with the laser marker (see "Photocell" on page 35). HIGH level pulsed signal start the marking process (refers to Lighter™ user's manual "Setting I/O parameters" paragraph to set the signal properties)
	Lighter™ is not set in <i>AUTO MODE / WORK MODE</i>	Check that Laser Engine is set in <i>AUTO MODE</i> or that Laser Editor is set in <i>WORK MODE</i>
Laser marker doesn't work in Marking On Fly mode	MOF is not enabled or not configured	<ul style="list-style-type: none"> - Use the Laser Engine <i>MOF</i> wizard to setup the laser marker (refers to Lighter™ User's Manual) - Check that the <i>MOF MODE</i> is enabled (refers to Lighter™ User's Manual)
	Laser Engine is not set in <i>AUTO MODE</i>	Check that Laser Engine is set in <i>AUTO MODE</i> (refers to Lighter™ User's Manual)
	Incorrect encoder's type or connection	<ul style="list-style-type: none"> - Check that the encoder is compatible with the laser marker (see "Encoder" on page 35) - Check that the encoder is working using Laser Engine <i>MOF</i> wizard (refers to Lighter™ User's Manual)
	Incorrect photocell type or connection	<ul style="list-style-type: none"> - Check that the photocell is compatible with the laser marker - Check that the photocell is working using Laser Engine <i>MOF wizard</i> (refers to Lighter™ User's Manual)
	Inappropriate layout	Check that the layout to engrave is compatible, in terms of marking time, with the <i>MOF</i> application

PROBLEM DESCRIPTION	POSSIBLE CAUSE	ACTION
Red Aiming Beam not visible	F-Theta Lens protection not removed	Check that the F-Theta scan lens protection has been removed
	Laser marker is not in the correct state	Check that the laser marker state is coherent with the <i>AIMING BEAM TYPE</i> property set in Laser Engine Configuration " LASER " (refers to Lighter™ User's Manual)
	Incorrect <i>Aiming beam setting</i> in Laser Engine	<p>Check <i>STANBY POSITION</i> property in Laser Engine Configuration "SCANNER". Depending on the setting, the aiming beam could be not visible because pointed outside the marking field (refers to Lighter™ User's Manual)</p> <p>Check <i>AIMING BEAM TYPE</i> property in Laser Engine Configuration "LASER" (refers to Lighter™ User's Manual)</p> <ul style="list-style-type: none"> • OFF: always OFF • AUTOMATIC: active only in STANDBY SHUTTER CLOSED state
X, Y, Z, R Axis doesn't work	Incorrect integration	Check that the <i>X2 - Axes control signals</i> are compatible with the external devices used for integration
	Axis is not enabled	Check that the selected Axis is enabled in Laser Engine Configuration (refers to Lighter™ User's Manual)
	Axis is not correctly configured	Check that the selected Axis is correctly configured in Laser Engine Configuration (refers to Lighter™ User's Manual)
Windows settings are not saved at system restart	C:\ drive is write protected by UWF filter	Follow the procedure present in "System Protection Tool" on page 66
Generic I/O signals doesn't work	Incorrect integration	Check that the I/O control signals are compatible with the external devices used for integration
	I/O already used by Axis	Generic I/O and Axes share the same I/O signals. Check that the selected I/O are not used by an Axis that is enabled

REMOTE ASSISTANCE

The laser marker is equipped with a remote connection tool that can be used for diagnostic purposes by Datalogic technical support.

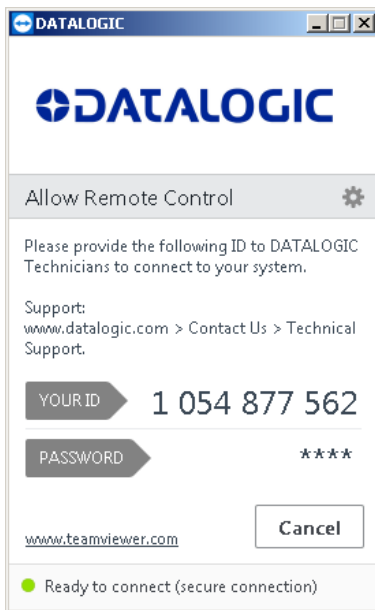



NOTE: The laser marker must be connected to the Internet.

APPENDIX A

LABELS

LABELS

LABEL	DESCRIPTION
	Identification label
	Warning laser logotype
	Laser Label (resonator) (*)
	Laser Label (control rack) (*)
	Aperture Label
	Label for non-interlock protective housing
	Caution, possibility of electric shock
	General Warning
	USB port
	MAC Address
	Control Rack fuses

LABEL	DESCRIPTION
 2xF2A	Resonator Fuses
	Windows 10 IoT Enterprise COA
0 - I	KEY/ENABLE positions
X1	Command Box connector
X2	Control Axes connector
INTERLOCK	Interlock connector
INTERLOCK OUT	Interlock OUT connector
LAN	LAN connector
RS232	RS232 connector
VGA	VGA connector
PHOT	Photocell connector
ENC	Encoder connector
RES	Resonator connector
MDR	Scan Head connector
RF	Radio frequency connector
FAN	Fan connector

(*) Maximum output of laser radiation as per definition 3.55 of IEC60825-1 considering single fault conditions.

POSITIONING OF EXTERNAL LABELS

Positioning of labels on the control rack:

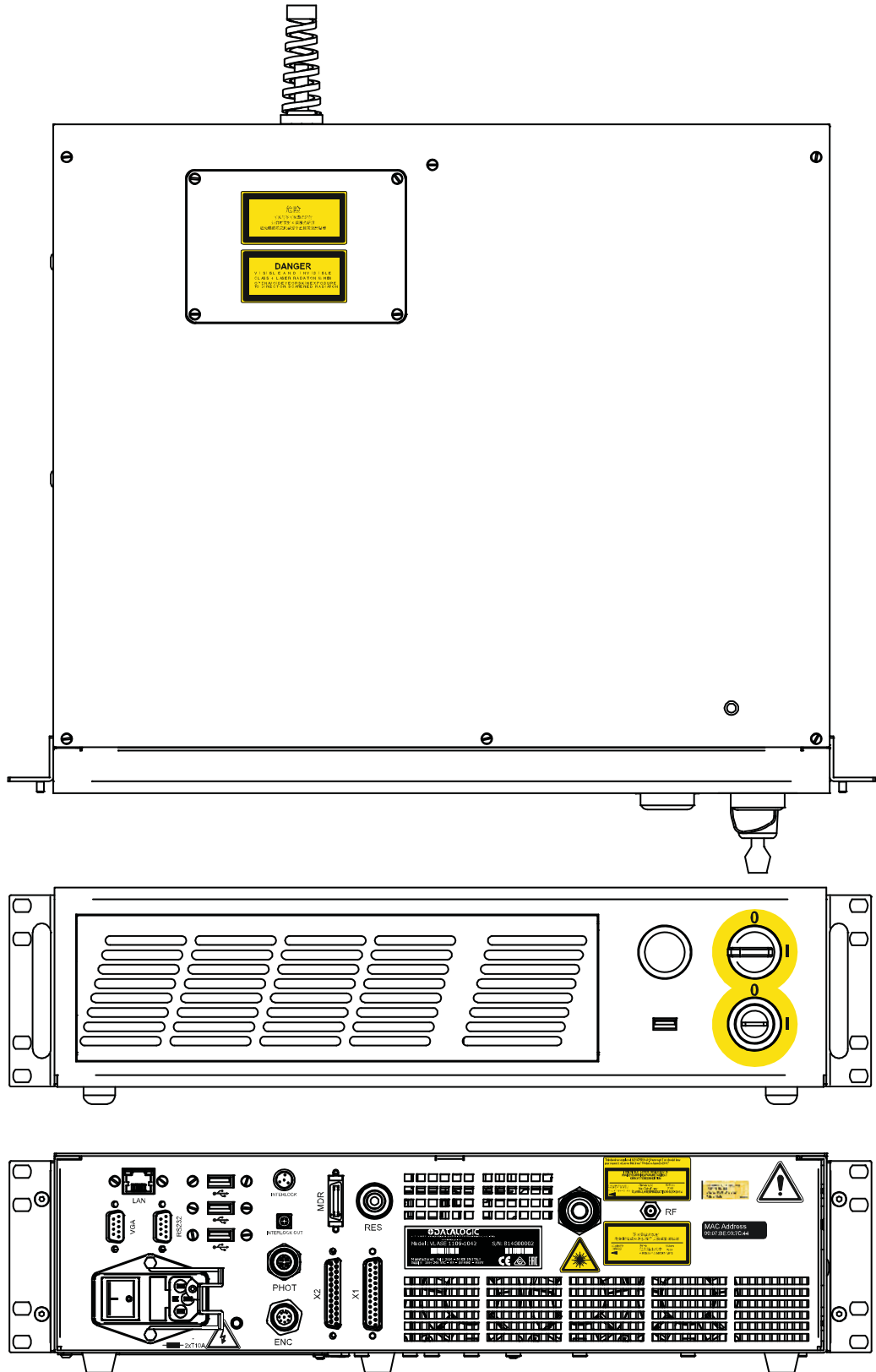

Figure 76: External labels rack location

Positioning of labels on the resonator:

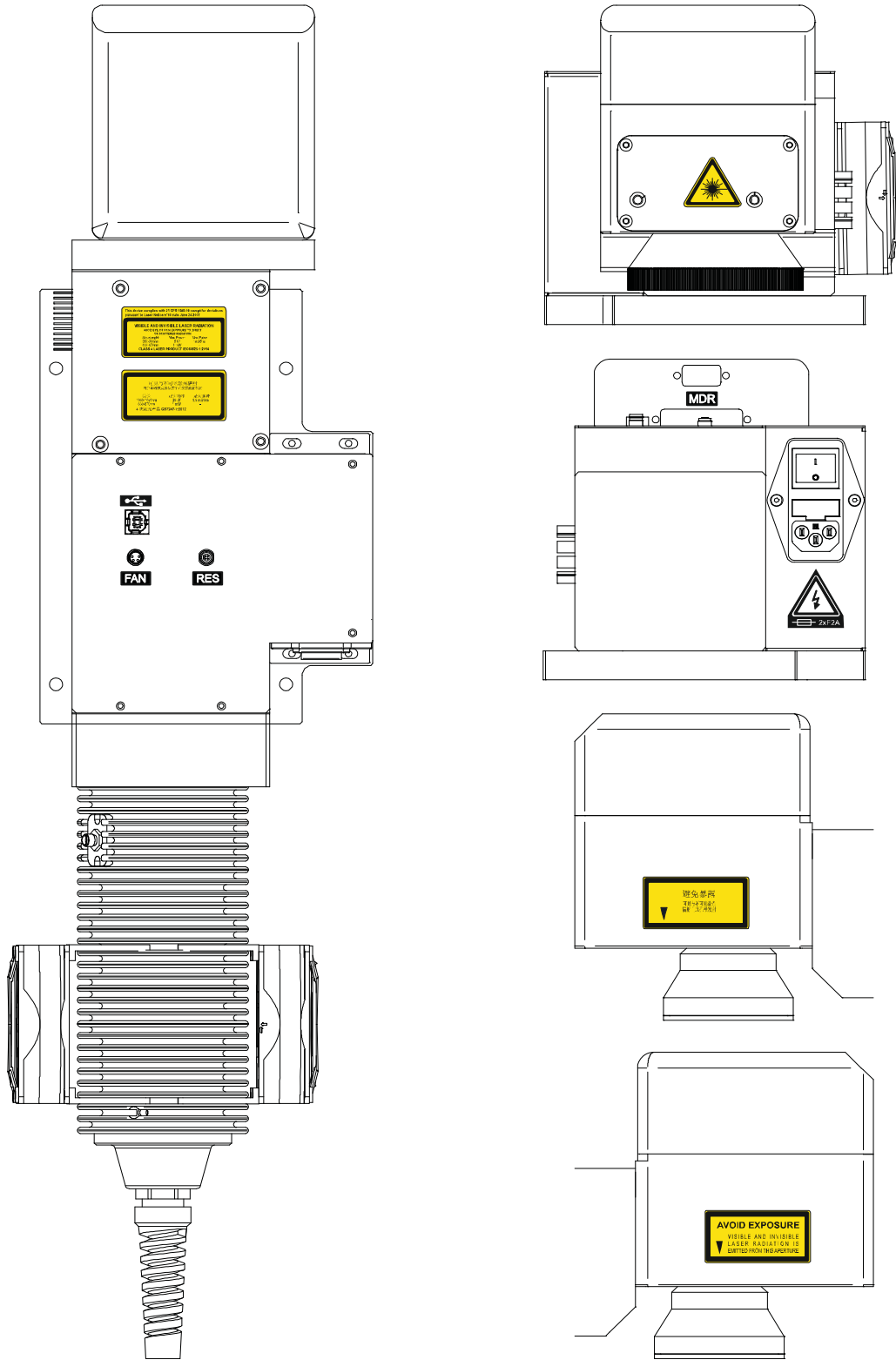

Figure 77: External labels resonator location

APPENDIX B

SAFETY CONSIDERATION

ACCORDING TO EN ISO 13489-1:2008

PERFORMANCE LEVEL (PL)

The PL is specified in EN-ISO13849-1. The risk analysis will lead to a PLr (Performance Level required) for a safety function based on the following graph:

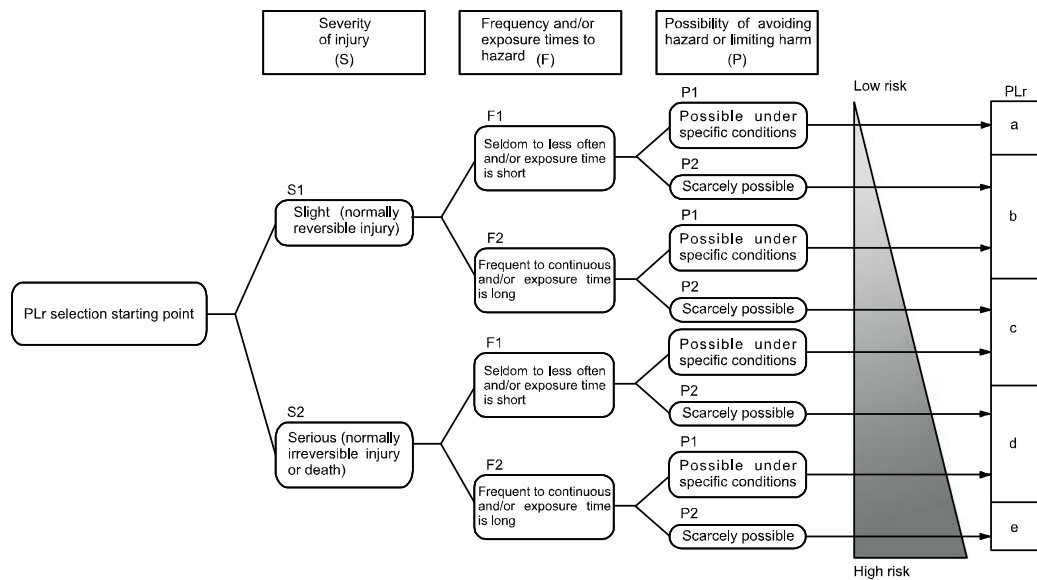

Figure 78: Determining the required Performance Level (PLr)

Application example



CAUTION: This example relates only to the features introduced in Vlase™ to assist in the risk reduction from the laser radiation. Any other risks (mechanical, electrical, etc.) must always be evaluated and appropriate risk reduction measures must be taken where necessary.

The Machinery Directive and EN 13849-1 are NOT applicable to the product Vlase™.

The target safety integrity or performance level (e.g. PLd according to ISO13849-1) shall be determined by the machine integrator, taking into account the machinery directive, the harmonized standards and any sector-specific standard that may apply.



CAUTION: This example is based on the parameters indicated in paragraph “Safety functions of Vlase™” on page 99.

Example automatic production line

In this case the Protective Housing may have a guard capable of being opened or removed, typically only for service operation (frequency: seldom or occasional):

- Guard opening should only be possible with the aid of a tool.
- Guard safety switch is connected as input of a safety logic and Vlase™ interlock system as output/input of that safety logic.
- Warning label for access panel according EN60825-1 must be applied.



Since the frequency is LOW (F1) and the removal of the guard is intentional, the MINIMUM REQUIREMENT as per IEC13849-1 is PLc.

Target: PLr = c

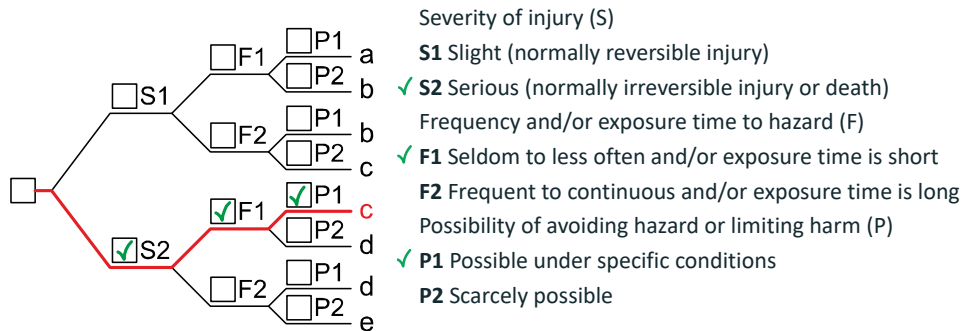

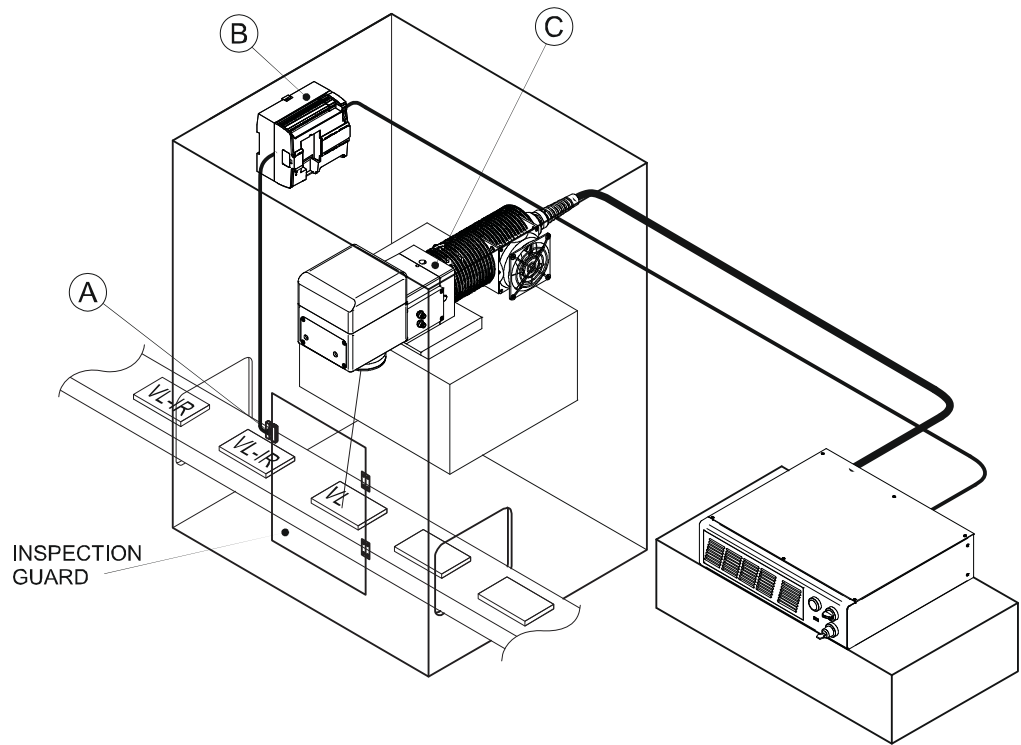

BLOCK DIAGRAM

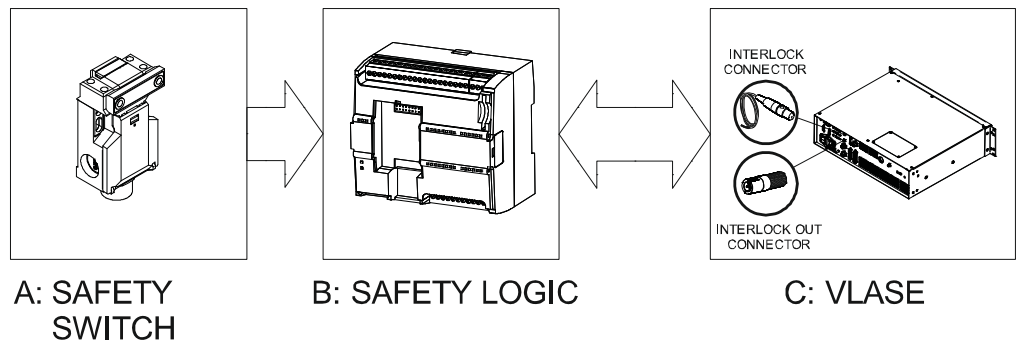

Vlase™ safety logic details for automatic production line

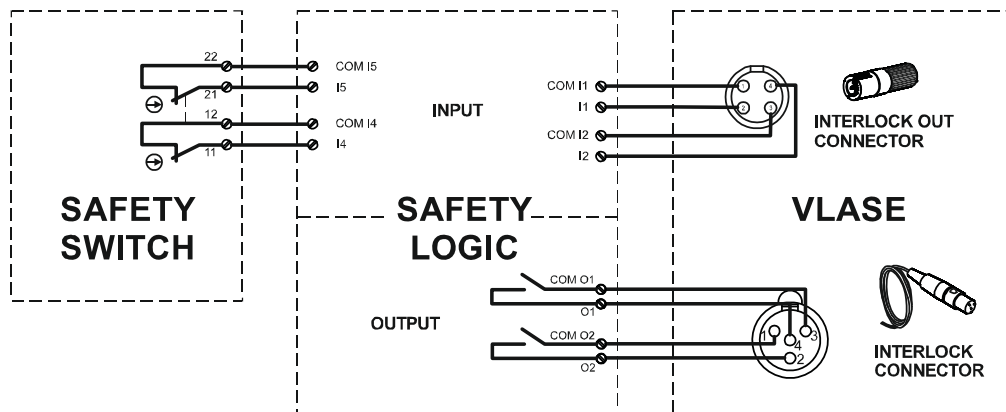

PLC Safety Diagram

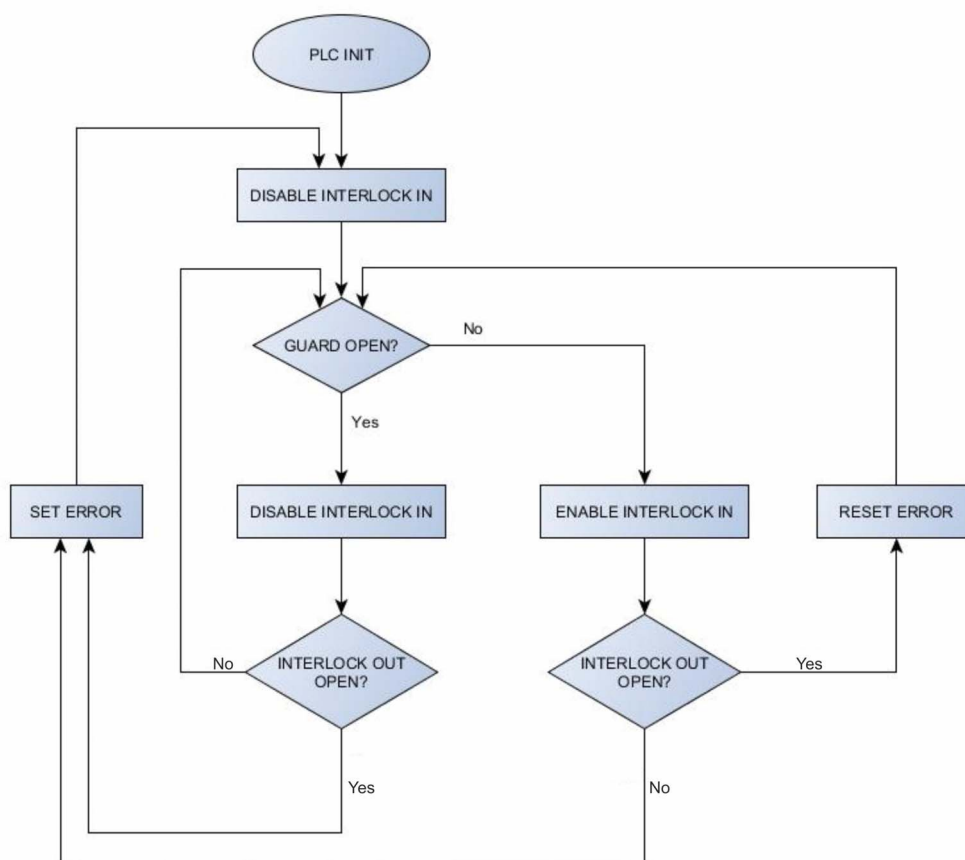

INTERLOCK_A	INTERLOCK_B	IN_OUT_A	IN_OUT_B	CONDITION
OPEN	OPEN	CLOSED	CLOSED	SAFE
CLOSED	OPEN	CLOSED	OPEN	DANGEROUS
OPEN	CLOSED	OPEN	CLOSED	DANGEROUS
CLOSED	CLOSED	OPEN	OPEN	DANGEROUS

Table 12: Truth table under normal conditions.

COMPONENT CHARACTERISTICS

DOOR SWITCH: SAFETY SWITCH, designed in compliance with the standard currently in effect IEC60947, EN292, EN60204, EN1088. Two redundant contacts. IP67. B10d=2000000.

SAFETY LOGIC: main component SAFETY PLC min. PLd according EN13849-1. Output type relays, min 10mA. To be installed in an IP54 enclosure.

CONCLUSIONS

Because MTTFd is greater than 100 years, Category is 3, max achievable DC is 99%, so this example satisfies the PLr=c.

SAFETY FUNCTIONS OF VLASE™

Vlase™ provides inputs, outputs and actuators to implement the following safety functions:

- SF.1 ENABLE (e.g. no UV laser output if “EXT_ENABLE_A” or “EXT_ENABLE_B” are disabled, where “disabled” means contacts open)
- SF.2 INTERLOCK (e.g. no UV laser output if “INTERLOCK_A” or “INTERLOCK_B” are disabled, where “disabled” means contacts open)

These functions have been evaluated according to UNI EN ISO 13849-1. The results are:

- **SF.1:**
 1. - Category: B
 2. - MTTFd <10 years
 3. - DC: none
- **SF.2:**
 1. - Category: 3
 2. - MTTFd = 4496 years
 3. - DC: feedback is provided. The determination of the diagnostic coverage (DC%) is assigned to the system integrator depending on the supervision system in place.
 4. - Response time: 10ms

APPENDIX C

LASER SAFETY

The following information is provided in compliance with regulations set by International Authorities, and it refers to proper use of the laser marker.

LASER RADIATION

Laser radiation is an electromagnetic emission with a micrometric wavelength which ranges from the long infrared (CO₂ Laser), close infrared (Nd Laser: Yag, Nd: YVO₄), visible (He Laser: Ne or Argon) and ultraviolet (excimer laser).

It should be considered non-Ionizing Radiation. In the Vlase™ laser marker, the emission of a crystal bar is stimulated by “optical pumping” generated by a Diode Laser. The continuous reflection of Photons, between a front mirror and rear mirror, creates a positive reaction so that their number continues to increase, until reaching the concentration necessary to produce a beam which projects from the semi-reflecting front mirror. The radiation (which we can imagine as a “Beam of invisible light”) is then Collimated and Focused with Lenses at a point where the intensity becomes high enough to be able to react with various materials producing an alteration in them due to thermal effect.

The radiations of the Vlase™ laser marker are visible and invisible and the Eye receives it almost in its entirety without using the natural defense provided by pupil reflex! Added to this is the fact that it is generally very intense, with the result that it can be very harmful to the eye and present vision problems.



WARNING: Directly viewing a laser beam can cause irreversible damage to human eye.

To prevent permanent damage to vision, a few precautions must be taken.

All individuals who may be exposed to dangerous levels of laser radiation, must know that the laser is active and wear protective goggles if necessary.

Due to its high power, the laser integrated in the Datalogic system provokes reflected laser light from flat surfaces. Reflected light is potentially dangerous for the eyes and skin. Electromagnetic emission with a micrometric wave length is placed in long infrared, and is therefore invisible, thus it is not clear where reflected beams are aimed.



WARNING: Viewing of a reflected laser beam can cause irreversible damage to human eye. The use of accessory external optics may increase the risk of damage.

In addition to possible injuries to human eye and skin, these lasers can ignite flammable materials and cause fires even at long distances.



WARNING: This laser marker is classified as Class 4. Class 4 Lasers can cause damage, not only from direct or reflected laser radiation, but also from scattered radiation. These lasers cause significant risk of irreversible damage to human eye and skin as well as risk of ignition and fire of flammable materials, even at long distances from laser radiation output aperture.



WARNING: Make sure that no flammable objects/materials are within the laser beam path. Use only non-flammable materials for enclosures or any other machine surfaces that may be exposed to direct or indirect laser beam radiation.

ABSORPTION OF LASER RADIATION

Human tissues absorb electromagnetic radiation in different ways depending on tissue characteristics and the wavelength of the radiation. Certain wavelengths may be transmitted or absorbed, in different levels, by the human tissue. In the specific case of the eye, the Cornea and Crystalline lens allows most of the radiation within the wavelength range of 400nm to 1400nm to pass and reach the retina (where are the vision sensors). This range includes the visible light as well as near-infrared. The Vlase™ laser markers emit in the 1064nm range and thus can be focused by the eye lens at retina with serious risk of causing irreversible damage to vision sensors.

Regarding human skin, the tissue absorption level is higher for the same wavelength range but the maximum exposure tolerance level, before there is a damage, is different compared to eye.

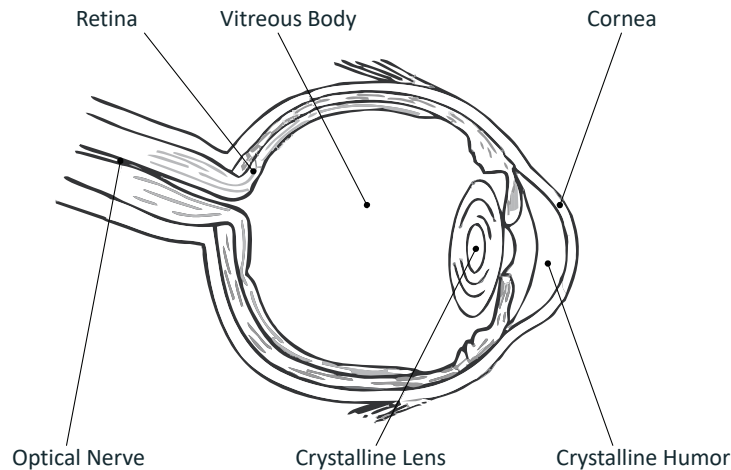

Figure 79: Eyeball section

The degree of injury depends on the amount of absorbed radiation; the power, energy and peak power of the radiation source, as well as the time exposed to such radiation.

CLASSIFICATION AND DANGER LEVEL

Regulations have established different classes of Lasers, based on their ability to cause human injury. These classes ranges from Class 1 (basically safe in all conditions) to Class 4 (dangerous in several conditions).

Lasers that can produce risk to human being, not only from direct or reflected radiation but also from scattered radiation, belong to Class 4. These lasers sources can also present risk of causing fires through ignition of flammable materials. For these reasons the Customer must, when integrating the laser marker into their machine, implement all necessary measures to contain laser radiation and ensure compliance with applicable safety regulations. All operators using lasers systems should also use appropriated individual protection devices such as goggles, etc.



WARNING: The Vlase™ laser marker contain Class 4 invisible laser sources. Refer to applicable regulations (including Laser Safety and Machine safety) for recommendations for compliance of your machine with integration and use of such Class lasers type.

DEGREE OF RISK WITH RADIATION VIEWING CONDITIONS

If F-Theta scan lens is removed from resonator the output radiation is a collimated intense coherent laser beam. The image of such a beam, created by any lens is then a very small spot with extremely high power and energy density. Such a beam is also focused by the human eye and thus result in irreversible damage to the retina. The output radiation of the laser marker, with the F-Theta scan lens, is not a collimated beam but a convergent (before focus plane) and divergent (after focus plane) laser beam. The degree of convergence and divergence depends on the F-theta scan lens specifications and thus varies with the different laser marker models. While marking the laser radiation is typically scattered at the object being marked. Special attention must my taken with objects with high reflectivity to the laser wavelength range since such objects may not only reflect the laser radiation but also change its characteristics according to the shape of such surface (that can work as a lens element). Thus the risk related with laser radiation depends on the characteristics of the beam at which the human is exposed.

In the following sections the risk degree to human eye, related with different viewing conditions, is qualitatively described. Please note that this is intended only as awareness on such risks.



WARNING: It is responsibility of Customer to makes an independent risk evaluation and to implement the necessary safety measures, according to applicable regulations, pertinent to Class 4 Lasers.

Direct viewing of the laser beam

This type of viewing is the most danger for human eye and can occur if looking directly into laser output aperture. Risk is higher in case F-Theta scan lens is removed since output laser beam is, in such conditions, collimated.



WARNING: Do not look directly to laser beam. Individual Protection Devices such goggles do not warrant protection for direct exposure to laser radiation.

Viewing of a laser reflected beam

This may occur when beam is reflected on a mirror surface. This type of viewing is as danger for human eye as direct viewing of the laser beam.



WARNING: Do not look to reflected laser beam. Individual Protection Devices such goggles may only provide protection for a short period of time and thus do not warrant protection for exposure to reflected laser radiation.



WARNING: Many materials, including metals and plastics, have surfaces that strongly reflect laser radiation. Make sure to use non-reflective materials for enclosures or any other machine surfaces that may be exposed to direct or indirect laser beam radiation. Pay special attention when marking objects with high reflectivity properties.

Viewing of direct laser beam from a fiber output

Although unlikely to happen since fiber is protected by an armored stainless steel cable, this may occur when Resonator Cable, that connect control rack with resonator is damaged and fiber is broke. The laser radiation is highly divergent but power and energy is high and risk is similar to direct viewing of a laser beam.



WARNING: Do not look to fiber output laser beam. Individual Protection Devices such goggles may only provide protection for a short period of time and thus do not warrant protection for exposure to direct laser radiation.

Viewing of scattered laser beam

This is the most typical exposure condition when laser is scattered by at a non-reflective surface (such as blocking element or when marking of some materials). In this case, special filter widows and Individual Protective Devices (such as goggles) may allow full protection even for prolonged exposures if is such protective means respect applicable norms for the type of laser radiation.



WARNING: Always use certified protecting goggles appropriated for the laser radiation characteristics to which you can be exposed.



WARNING: Remember that none goggles can provide sufficient protection for prolonged direct or reflected laser beams.

N.O.H.D. DETERMINATION AND O.D. OF PROTECTION GOGGLES

In order to determine the characteristics of the protection goggles, it is essential to determine the characteristics of the radiation, knowing its optical path, the dimensions of the beam and its divergence.

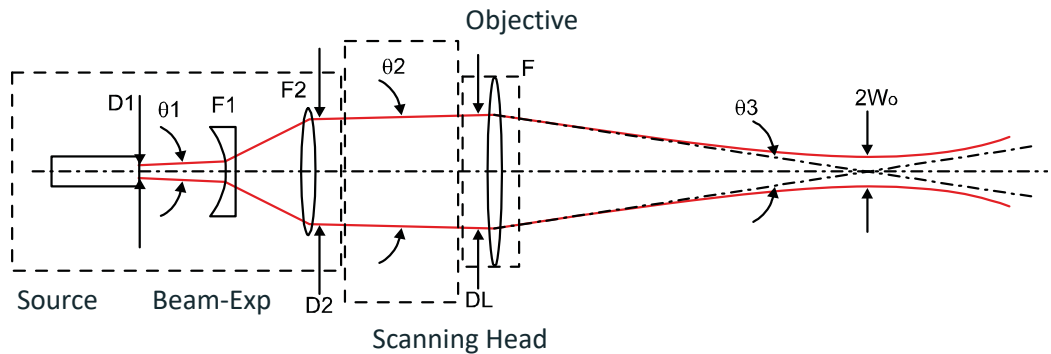

It is very important to know the real divergence of the laser beam at the output of the F-Theta scan lens.

With the availability of these optical data, it is possible to calculate the Nominal Ocular Hazard Distance (N.O.H.D.) and the Optical Density (O.D.) required by the laser radiation protection filters (goggles).

Below results have been done considering Directive 2006/25/CE on the minimum health and safety requirements regarding the exposure of workers to risks arising from physical agents (artificial optical radiation). The user must check if Directive 2006/25/EC was implemented as a law in his own country and regulate himself accordingly.

Only accidental direct exposure has been considered (exposure time = 10 seconds).

PARAMETER		3039-144X
Wavelength	nm	355
Pulse Energy	mJ	0.1 @ 30 kHz
Pulse Duration	ns	8
Beam Diameter (DL)	mm	6
M^2		2
Working Distance (WD) ^a	mm	197
Real Divergence after the lens (θ_3)	mrad	30.46
N.O.H.D. ^b	m	2.44
O.D. ^c		(D)>4;(R)>5

a. See Note on page 23

b. Assuming the F-Theta scan lens as reference point

c. Assuming the F-Theta scan lens as reference point, this O.D. is valid for a distance greater of 0.5 m + WD

EN207 and EN208

The O.D. value specifies the attenuation factor that the filter material theoretically has on the beam. However it does not specify the damage threshold of the filter material! The filter material may not be able to withstand the power of a particular laser and may fail instantaneously and result in serious eye injury.

In Europe, two standards have been developed for materials used as filters and frames for laser protective eye wear and laser protection windows. The EN207 and EN208 norms both specify the damage threshold of the filter material used.

The EN207 standard is used for full attenuation, these filters are used to completely block the wavelength for which they are specified.

The EN208 standard is used for partial attenuation, these filters are used only in the visible range 380-700nm where they reduce the beam intensity down to the Maximum Permissible Exposure (safe level). They are particularly useful for alignment where seeing the beam is necessary.

Safety goggles are labeled according to EN207 or EN208 as appropriate. For example, a filter labeled 300-400 R LB3 xxx CE means that:

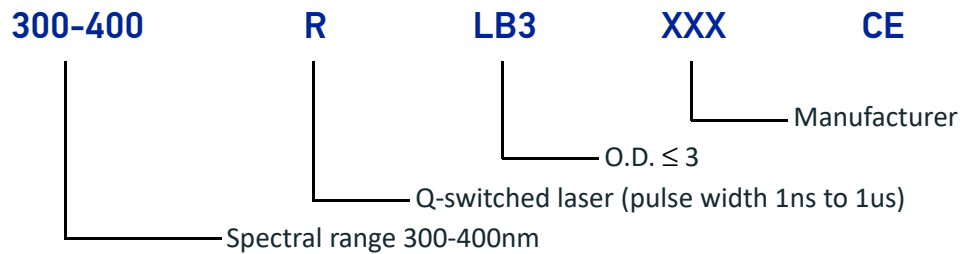

EYES AND SKIN RISKS

If exposed to intense Laser radiation, even of a short duration, or a less intense but longer lasting duration, both the Cornea and the Retina can burn and be damaged irreparably. This is particularly critical for Class 4 laser beam.

If subject to direct focused radiation, even the skin can burn.

GENERAL SAFETY REGULATIONS

The user of the laser marker must comply with all regulations and work best practices regarding safety. Therefore it is necessary to develop a Standard Operating Procedure (S.O.P.) related to operations of the machine incorporating this laser marker. This procedure, shall be available at time of installation, shall serve as a reference for the Operator and shall be written in his/her language.

Training is essential and must include:

- Familiarization with system operating procedures.
- Knowledge of the biological effects of radiation on the Eyes and Skin.
- Understanding of the necessity for Individual Protection Devices (I.P.D.)

OTHER RISKS

An additional risk may be represented by fire caused by processing materials other than those the laser marker was designed for.



WARNING: Do not use this laser marker for other purpose than the one it was designed for.

Another additional risk associated with the laser marker is electricity. This may occur when accessing internal parts of the laser marker.



CAUTION: Only Datalogic authorized personnel, who have been trained and instructed on the electrical and optical risks, is allowed to access the internal parts of the control rack.

Datalogic shall not be held liable for any damage caused by inadequate work from non-authorized personnel.



CAUTION: Only Datalogic authorized personnel, who have been trained and instructed on the electrical and optical risks, is allowed to access the internal parts of the resonator.

Datalogic shall not be held liable for any damage caused by inadequate work from non-authorized personnel.

APPENDIX D

USING MARKING SOFTWARE

HOW TO CREATE AND EDIT GRAPHICS LAYOUT



NOTE: This example considers that the laser marker is controlled in **Key Selector** mode (see “Preliminary operation” on page 60).

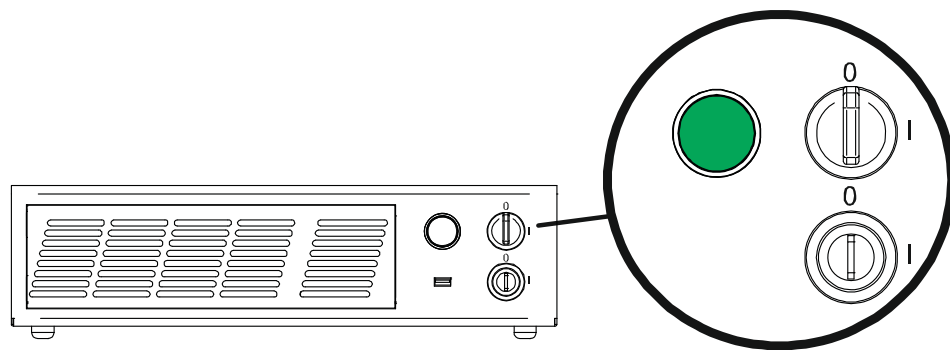

In “**WAIT FOR START**” state, double click the **Laser Editor** icon to start the layout editor application.

Click on the document type selector and choose **Layer**:

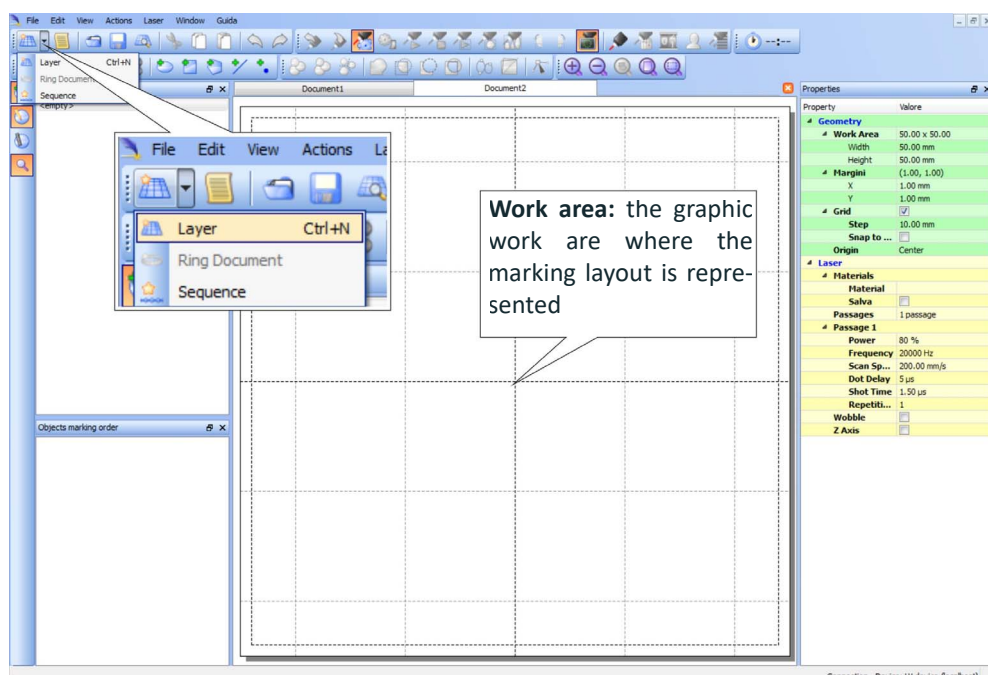

Click on the **Text String** icon in the **Object toolbar** to add a string object to the layer:

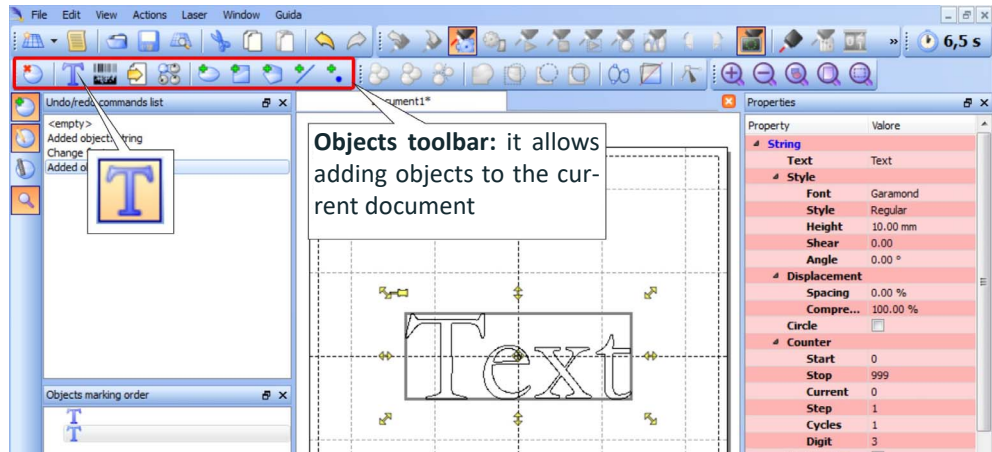

Edit String properties such as value, font, style, etc. using the **Properties browser**:

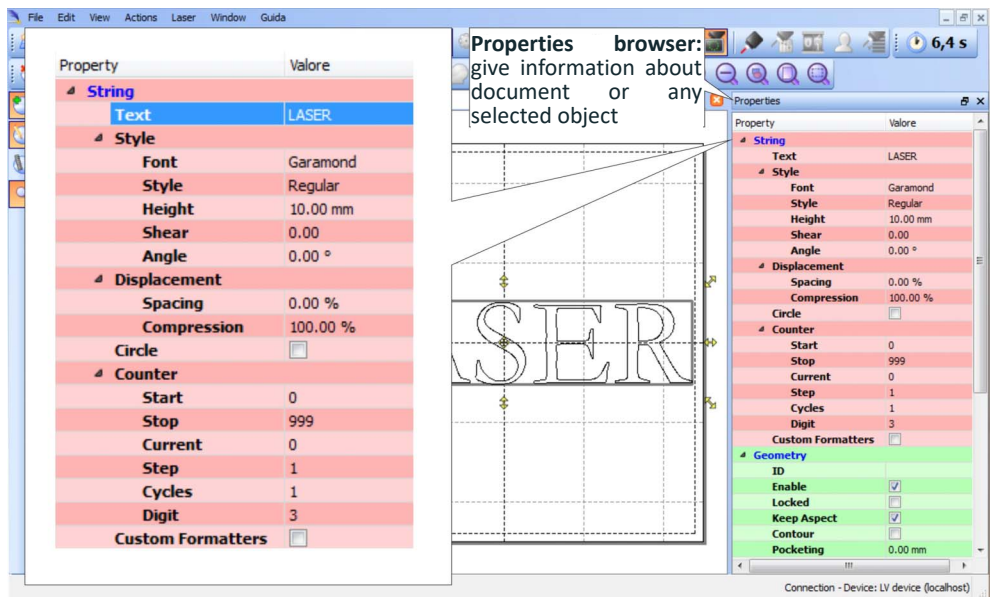

Edit Filling properties such as filling type, interline, etc. using the **Properties browser**:

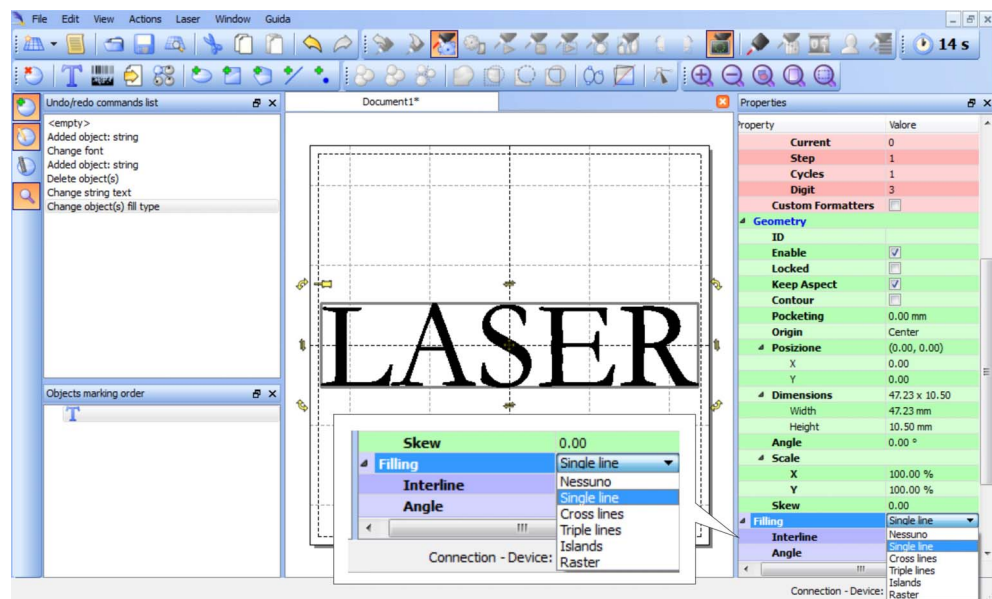

NOTE: Consult **Lighter™** software user's manual for a proper use of the same.

HOW TO TEST AND MARK LAYOUT

In “STANDBY SHUTTER CLOSED” state, press **Limits All** button in the **Laser Toolbar** to adjust the object position in the marking field:

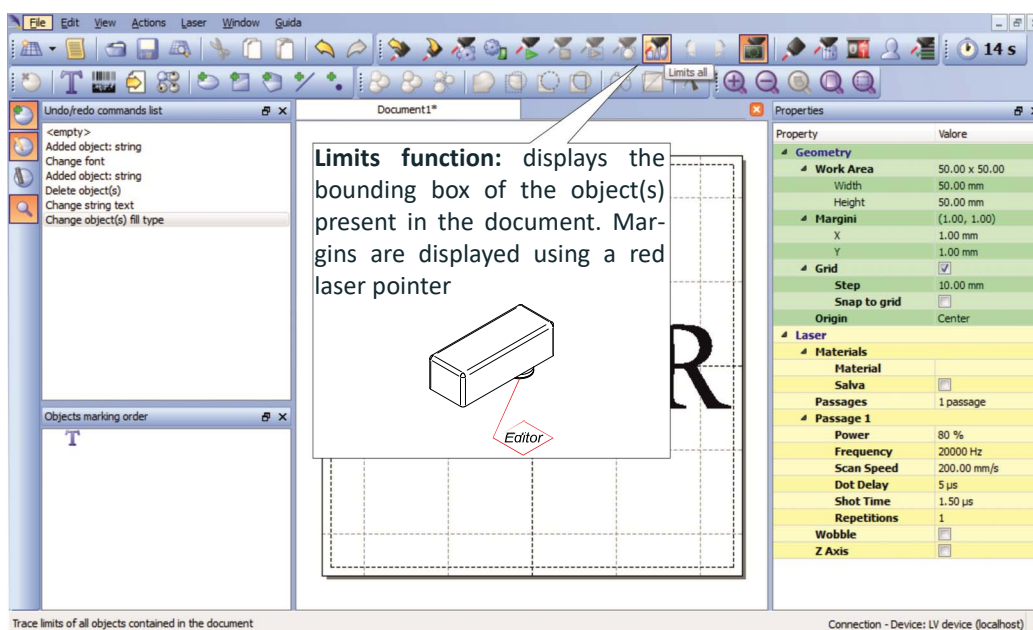
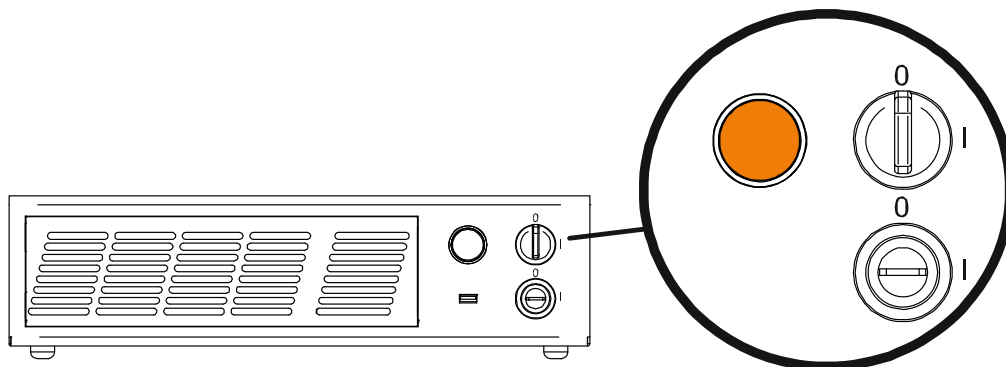

CAUTION: Marking highly reflective materials might cause optical feedback into laser marker. This may result into irreversible damage of the optical components of laser marker.

Verify that the position and geometry of the object to mark does not cause any reflection into the optical aperture of the laser marker F-Theta scan lens.

Please contact our Customer Support Service for support on your particular application.

Optical induced damage caused to laser marker by back reflection from high reflective materials is not covered by warranty.

In “READY” state, adjust the Laser parameters using the **Properties browser**:

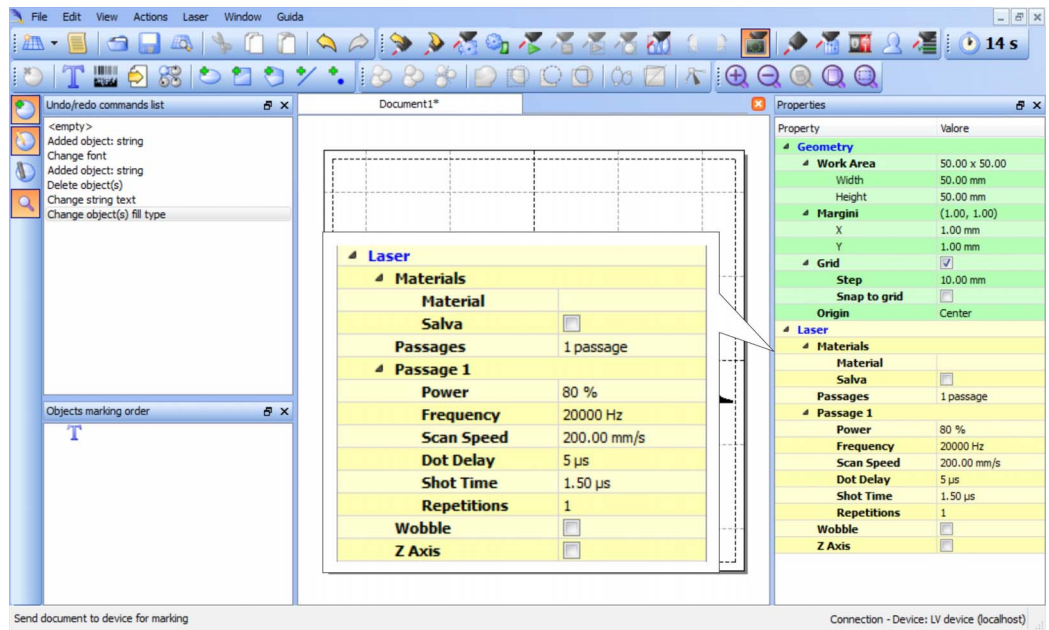
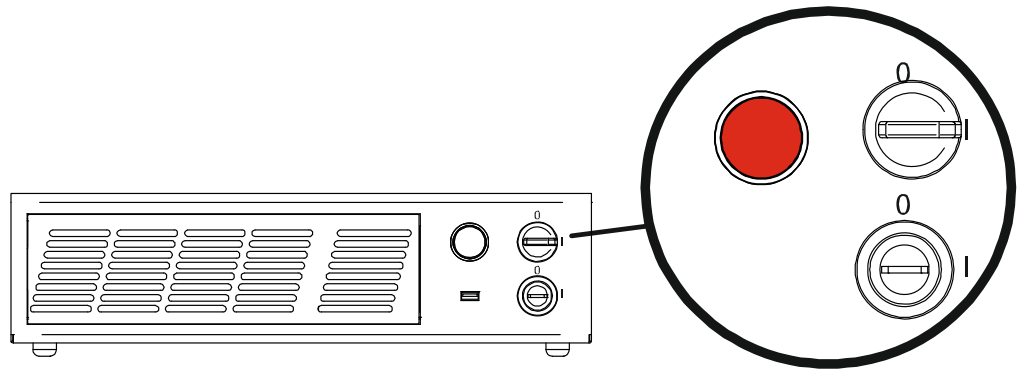

Press the **Send Marking** button in the **Laser Toolbar** .

HOW TO USE X1-COMMAND BOX SIGNALS TO MARK LAYOUT

Automate the marking process allowing documents to be marked using external **X1.11** (*START_MARKING*) and **X1.13** (*STOP_MARKING*) signals, which can be generated by PLC or other external devices.

Click on the **Save to Device** button to save the layout in the device memory:

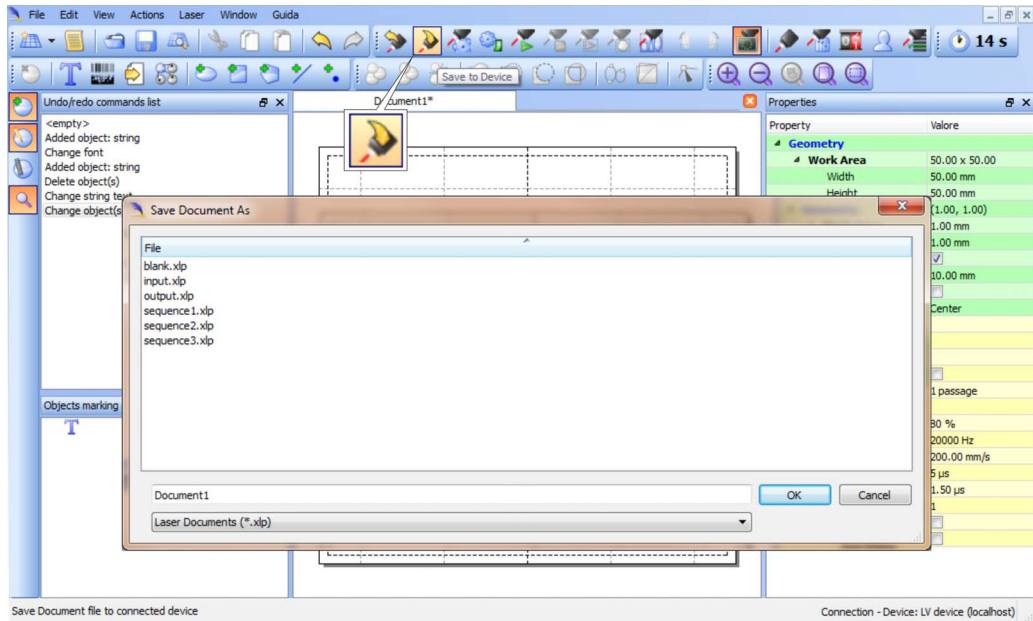

Click on the **Show Laser Engine** button to display Laser Engine window:

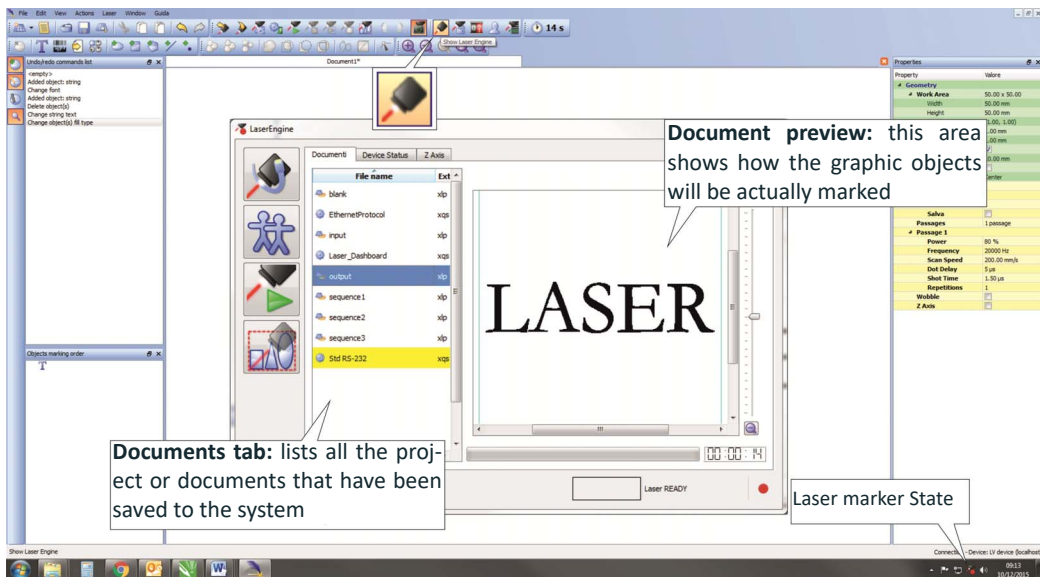

AUTO/MANUAL Mode button allows switching between the two available working modes:

- Auto mode: the engraving operations are executed automatically using external signals.
- Manual mode: used for displaying the margins of the graphic objects to be marked and to test layouts.

Select the document from the list and click on the **To Auto Mode** button:

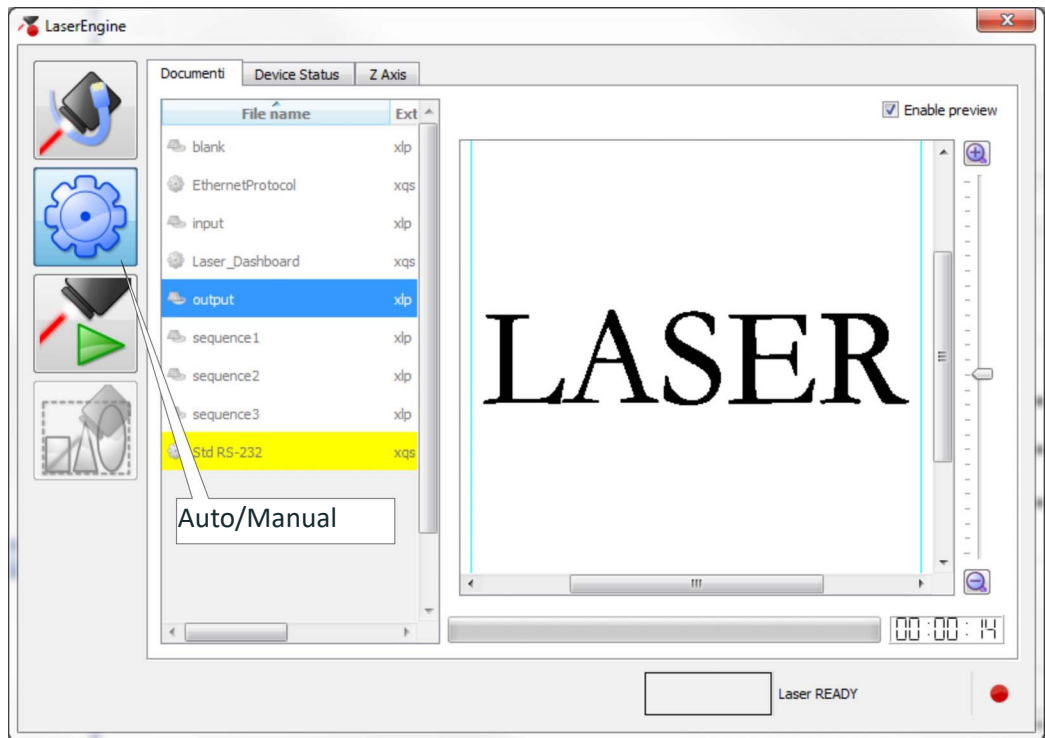

The laser marker is ready to mark the document using external **X1.11 (START_MARKING)** and **X1.13 (STOP_MARKING)** signals:

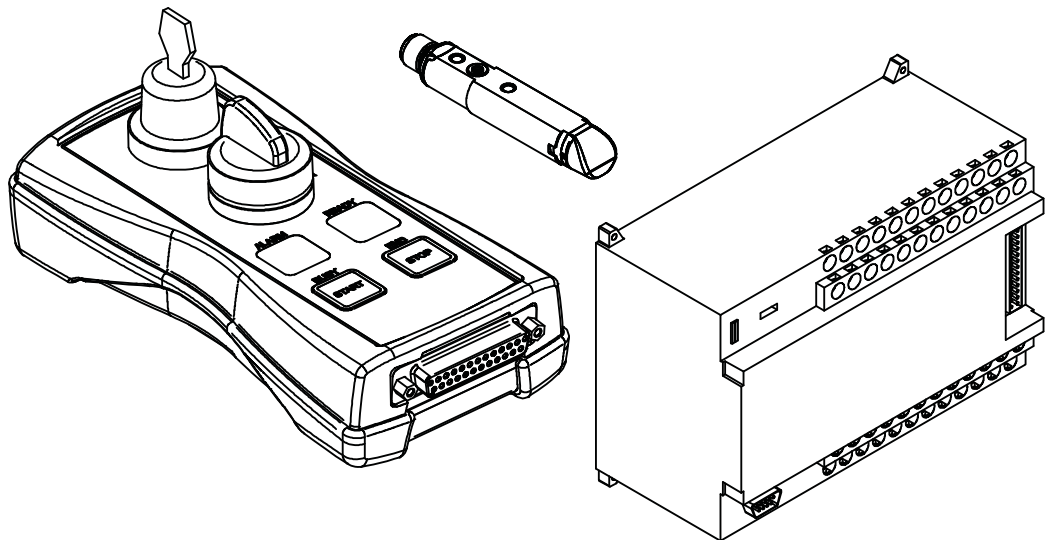

NOTE: Consult **Lighter™** software user's manual for a proper use of the same.

THERMALIZATION AND SUPPRESSION OF GIANT PULSES

Thermalization is useful in order to obtain a good marking quality.

To obtain uniform markings and work processes it is important to keep the Nd:YVO4 crystal constantly pumped. This operation is called thermalization and it is implemented by supplying the laser diode with a suitable level of current. In this way a certain amount of pumping radiation at 808 nm excites the crystal, but with the Q-switch closed, no laser radiation is emitted by the system.

With the Vlase™ source, this procedure can be implemented using Software Thermalization.

Software thermalization

Software thermalization is implemented automatically by the Lighter marking software and consists in defining, within the marking project, a certain thermalization level at which the crystal is maintained during the non-emission intervals. It is generally recommended to keep the level of thermalization similar to the power level used for the marking or slightly lower.

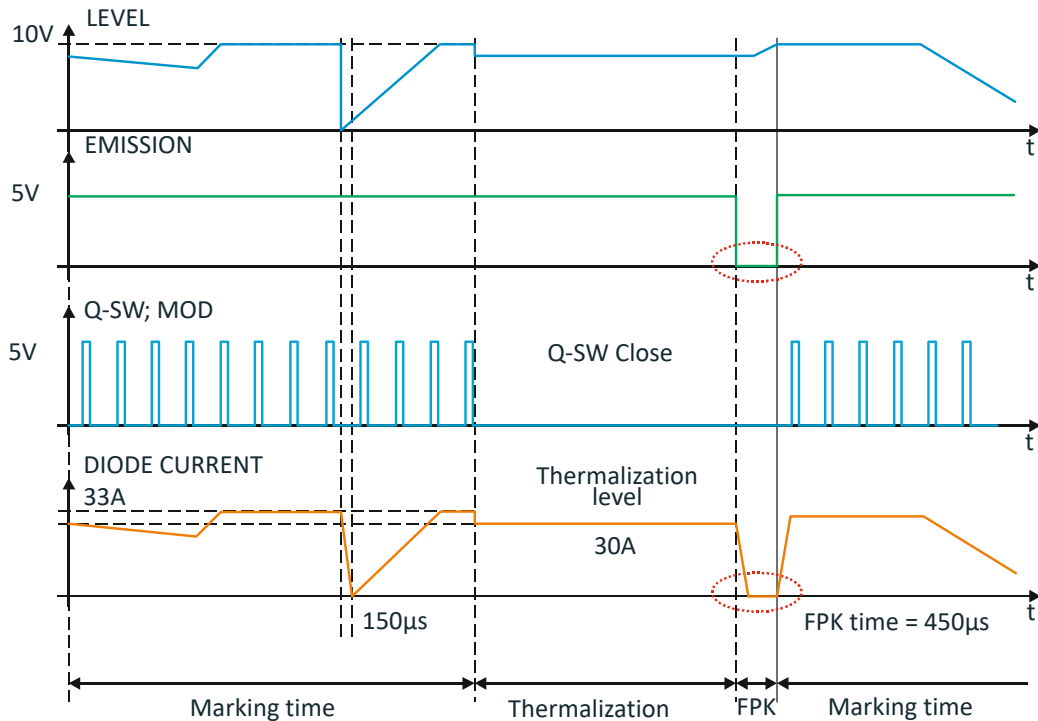

Figure 80: Temporal diagram of Software Thermalization

As you can see in the graph shown in the Figure, during the marking phase the Q-Switch Modulation signal determines the frequency with which the laser pulses are generated, the effect of the LEVEL signal is a corresponding change in the laser diode current.

Please note that, in order for this to occur, the EMISSION signal has to be active.



NOTE: Please also note that the current supplied to the laser diode is intentionally forced to have rising and falling times in the range of 150µs. This protection from rapid commutations (generated by faster changes of LEVEL or EMISSION signal fronts) is intended to reduce the risk of damage risk and extend lifetime of the diode itself.

During the thermalization phase, the EMISSION signal stays active, while the LEVEL signal goes into a pre-set thermalization level (i.e. 90%) and the Q SW MOD signal stays fixed at 0 V.

At the end of the thermalization phase, before starting another marking phase, the FPK (First Pulse Killing) procedure needs to be implemented in order to discharge the crystal, thus avoiding the generation of “giant” pulses which may cause marking defects as well as damages to the internal optics of the resonator.

To discharge the crystal, the Q-Switch is kept closed (Q SW MOD signal at 0 V) and the EMISSION signal is brought to a 0V level for at least 450 μ s, so as to cut off the current in the laser diode and consequently the pumping of the crystal (FPK delay).

LASER SOURCE	FREQUENCY INTERVAL	Q-SWITCH OPENING TIME (SHOT TIME)	OPTIMAL FPK DELAY
Vlase™ UV 3 W	20 kHz to 80 kHz	1,5 μ s	450 μ s



CAUTION: It is strongly recommended **NOT** to change the set FPK Shot time and delay, because they have been optimized to ensure the safety of the marking system and the performance marking linked to the high stability of the laser pulses.

APPENDIX E

MARKING SOFTWARE UPGRADE

HOW TO UPDATE THE MARKING SOFTWARE

This document describes how to update the Lighter™ Suite software version.

Before updating the software, disable system protection (see “Disable the system protection” on page 69).



CAUTION: When the System Protection is disabled the system is not protected against disk corruption or malware attacks. Disable the protection only for the time necessary to make disk changes.

1. Wait for the operating system to **restart**
2. Check that the System Protection is **disabled** (red icon):

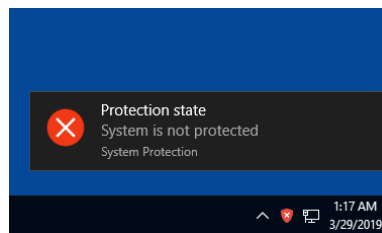

3. Close Lighter™ *Laser Editor and Laser Engine* (right-click on the icon in the tray bar and select **QUIT**)

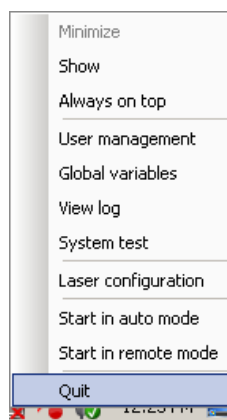

4. Run the new *Lighter™ Suite installer* from an external USB device.

5. Press **Next** to continue:

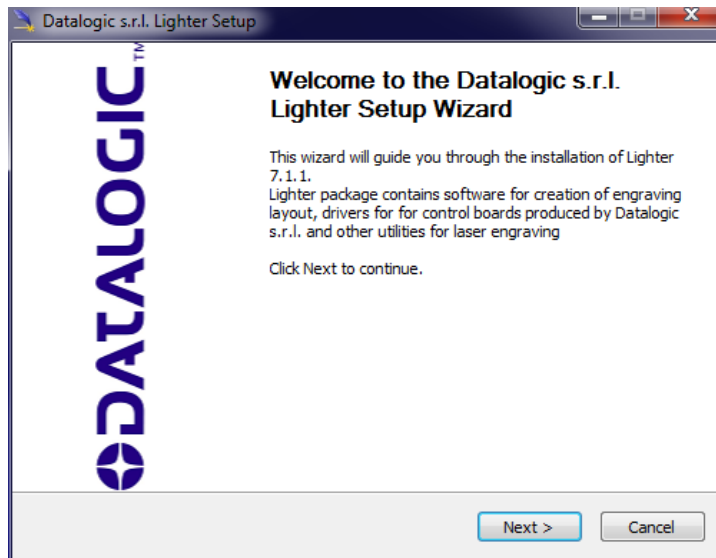

6. Press **I Agree** to continue:

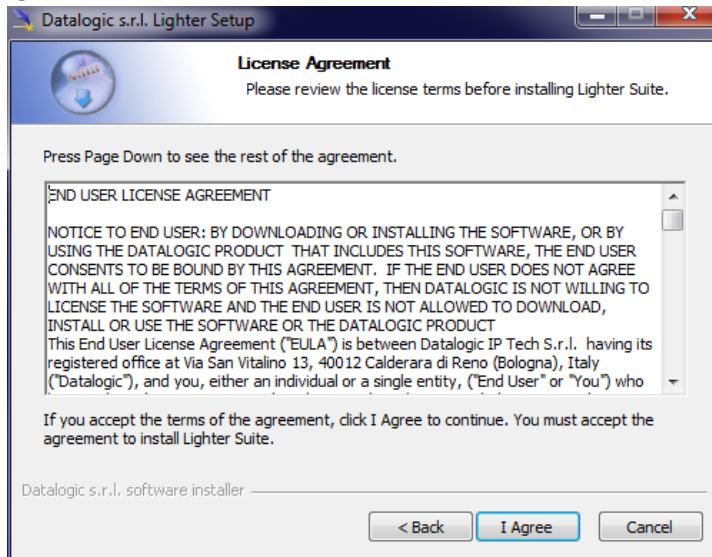

7. Check *"I accept the terms of the License Agreement"* and press **Next** to continue:

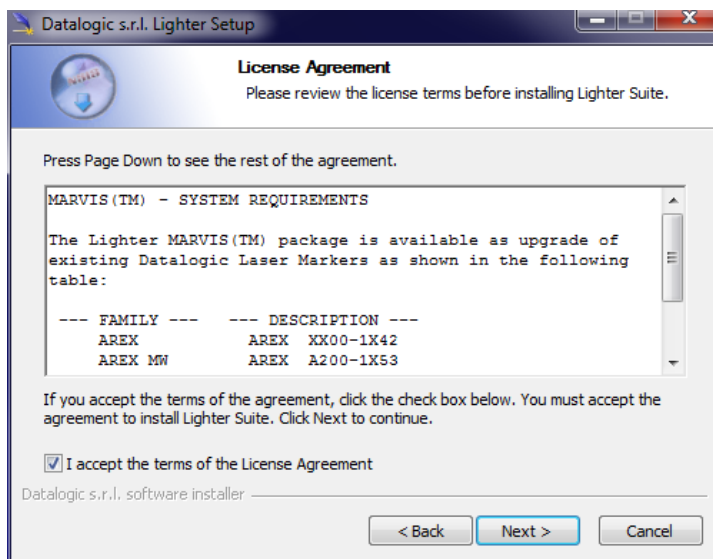

8. Choose the *INTERCATIVE* installation type and press **Next** to continue:

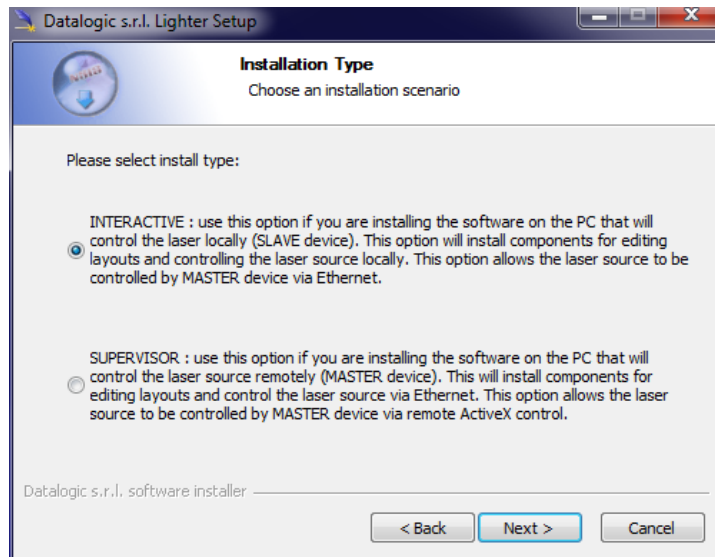

9. Choose the components to install and press **Next** to continue:

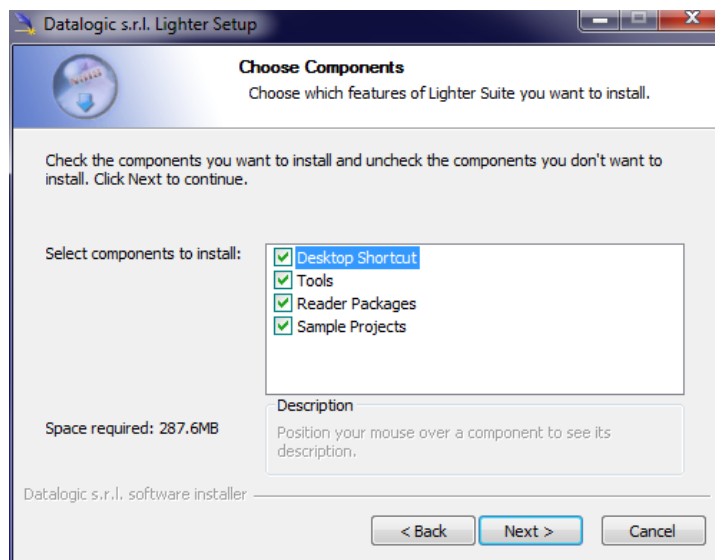

10. Do not change the destination folder and press **Install** to continue:

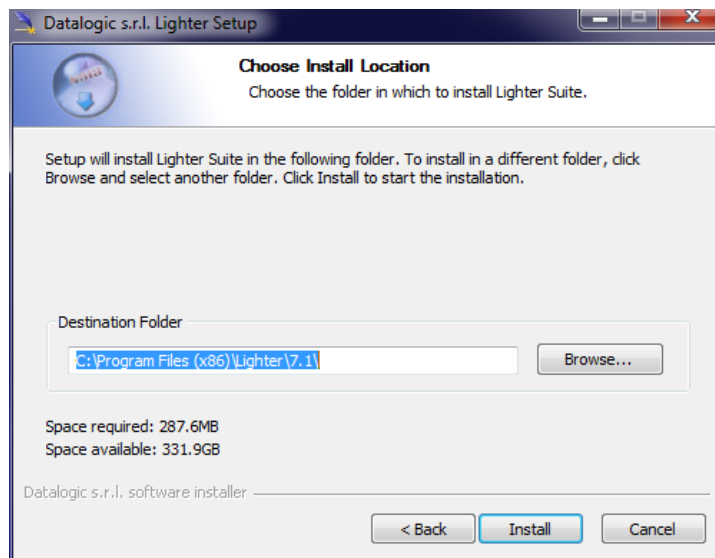

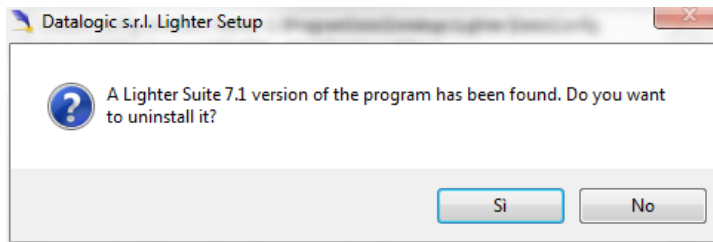
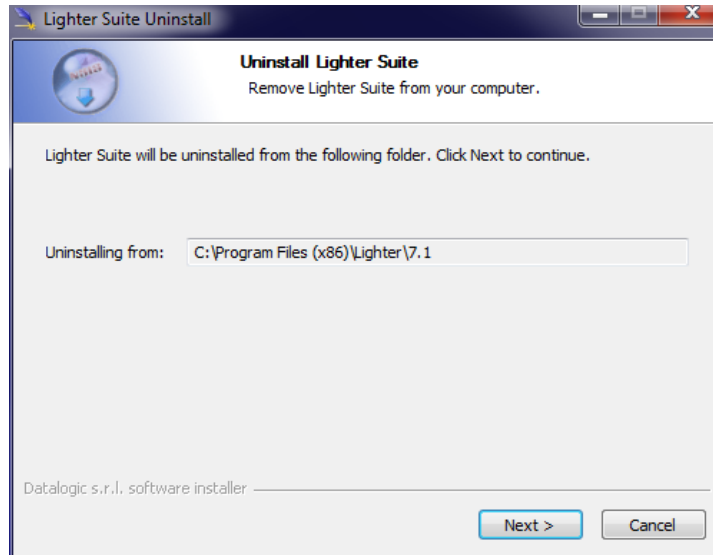
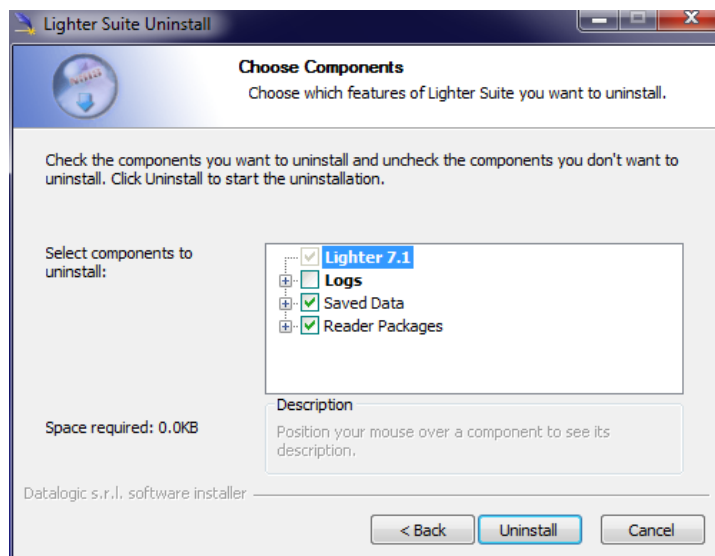
11. Press **OK** to uninstall the old Lighter™ Suite version12. Press **Next** to continue:13. Select the components of the old Lighter™ Suite version to remove and press **Uninstall**:

14. Wait until the unistallation is complete and press **Close** to continue:

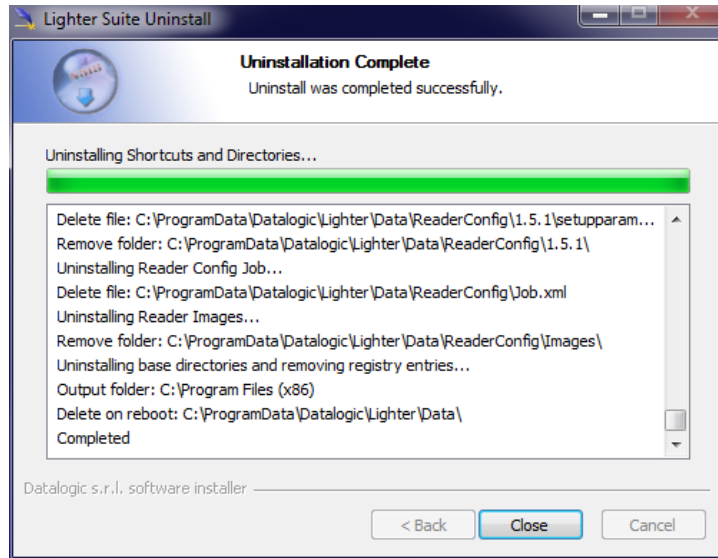

15. Lighter Suite will be installed. Press **Finish** to complete the procedure:

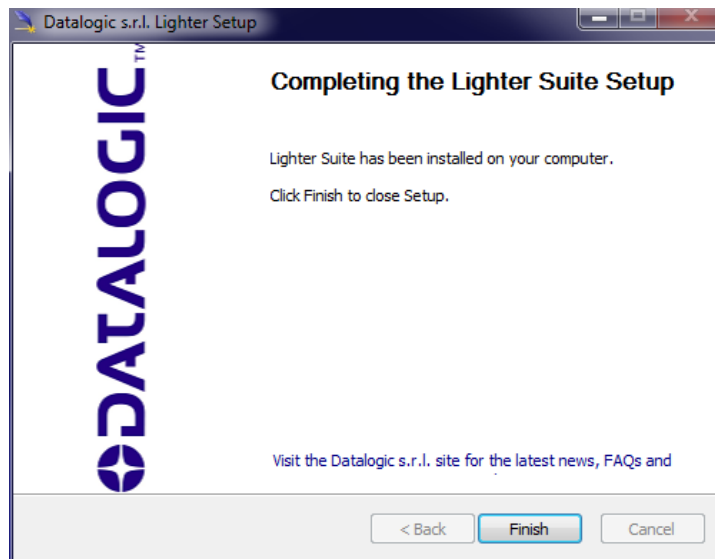

16. If Lighter™ Suite update includes any **control board updates** follow the procedure below otherwise jump to step 17:

- Procedure with laser control board upgrade:

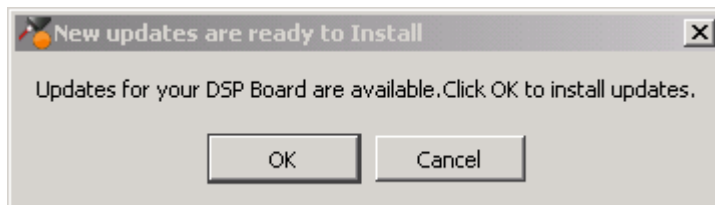

- press **OK** to execute control board update
- wait for the laser control board update

17. Open the System Protection tool GUI

- Click the **ENABLE** button

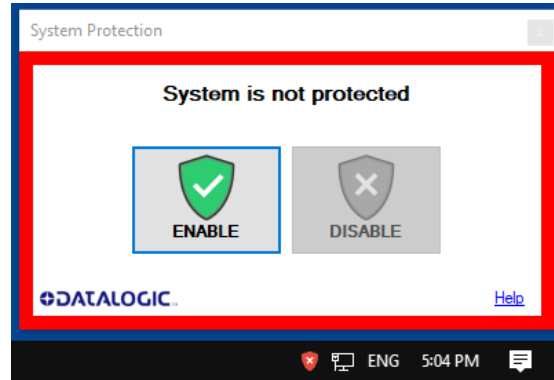

- A message advise the User to confirm the new setting. Press **YES** to enable System Protection

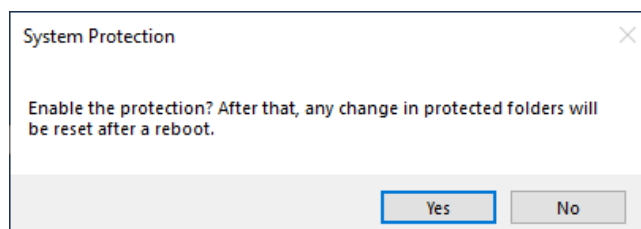

- A message advise the User that the system will be rebooted. Press NO to continue

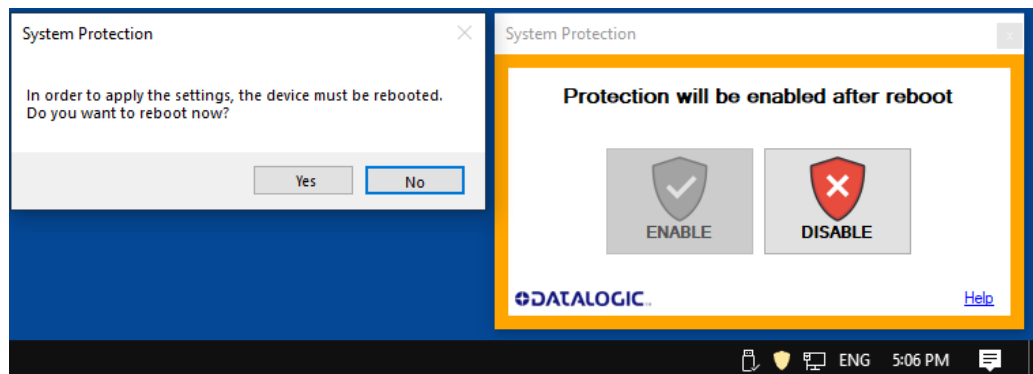

- Shut down the system:

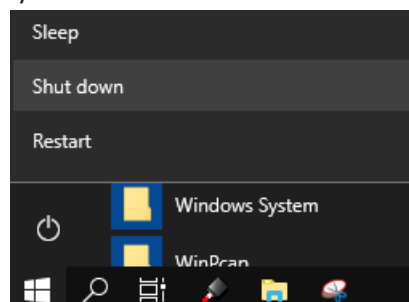

- wait until the operating system shuts down (black screen)



CAUTION: DO NOT turn OFF or UNPLUG the laser marker while Windows® is shutting down!

- **POWER OFF** the laser marker to complete installation

APPENDIX F

RECOVER THE LASER MARKER

OVERVIEW

The laser marker is provided with a *RECOVERY partition* able to restore the system to the factory settings.

The RECOVERY procedure should be used if the Operating System is corrupted or disks are corrupted.

HOW TO RECOVER THE LASER MARKER



CAUTION: All existing data in the laser marker will be overwritten. All existing data will be lost. If possible, make a backup of all the customer's data located by default in D:\Data folder, before recovering the system.



NOTE: The following images are indicative only.

Preliminary Operation

Before proceeding with the recovery procedure, it is necessary to get the original factory configuration file (`laser.inz`):

1. From an external PC connected to the Internet, go to [Datalogic](#) web site and click on **PARTNER LOGIN**.
2. If you are not registered yet, you will be asked to **Create your login**.
3. Enter **Username** and **Password**.
4. Select **TECHNICAL** and click on **LASER MARKING CONFIG. FILES REPOSITORY**.

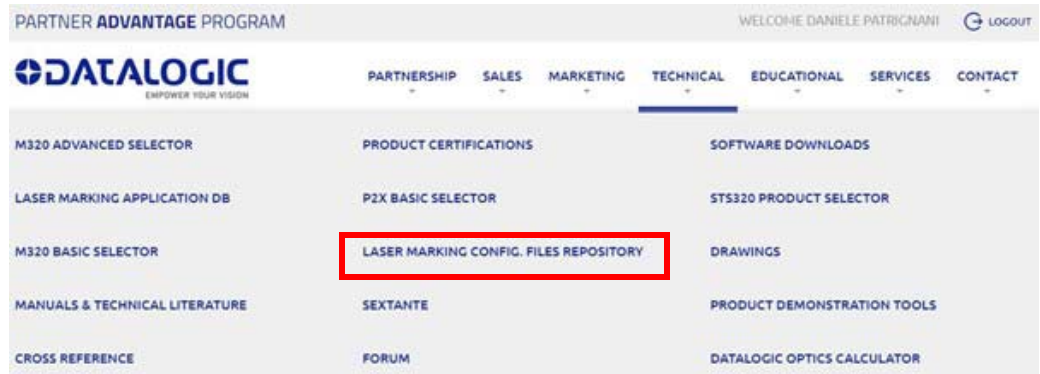

5. Insert the **Serial Number** and press **SEARCH** button.
6. Select **CLICK HERE** to download the file in **zip** format.



Search by serial number (for example B21M00135)

Configuration file found.
Please **CLICK HERE** to download the file.



7. **Extract** the content of the **zip** file in a USB drive (the file `laser.inz` is contained in the folder **Fileinz and report**).

Recover the system

1. Turn **ON** the laser marker
2. Wait for '**Choose an operating system**' menu to appears
3. Select '*Change defaults or choose other options*' using **TAB** key and then press **ENTER** key

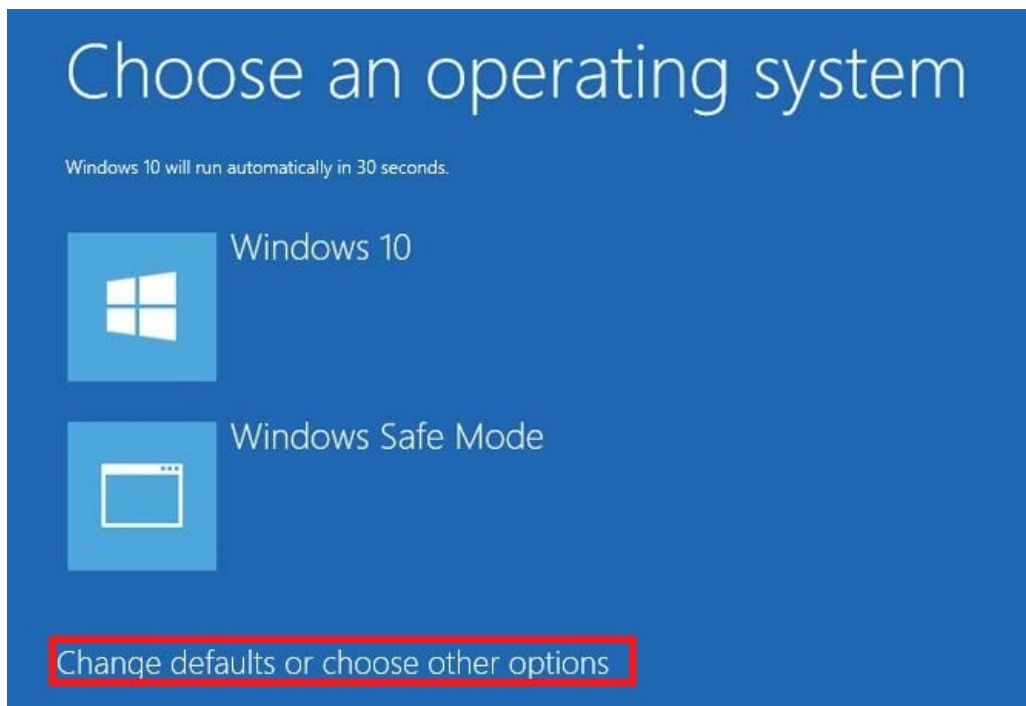

4. The **Options** screen will be shown
5. Select '*Choose other options*' using **TAB** key and then press **ENTER** key

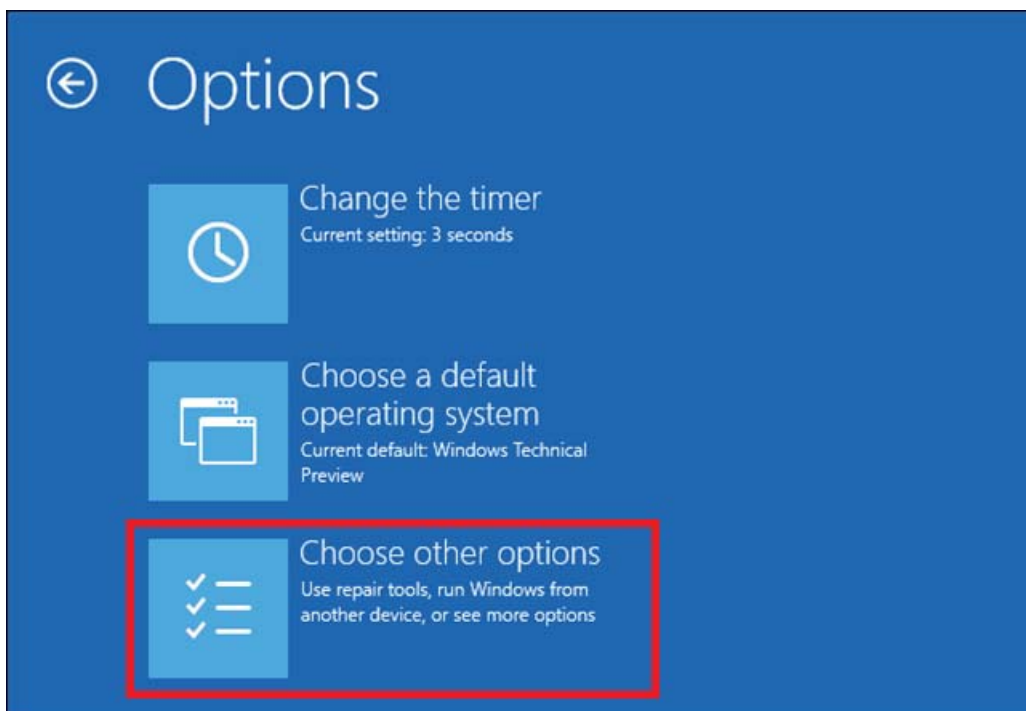

6. The **Choose an Option** menu will be shown
7. Select '*Troubleshoot*' using **TAB** key and then press **ENTER** key

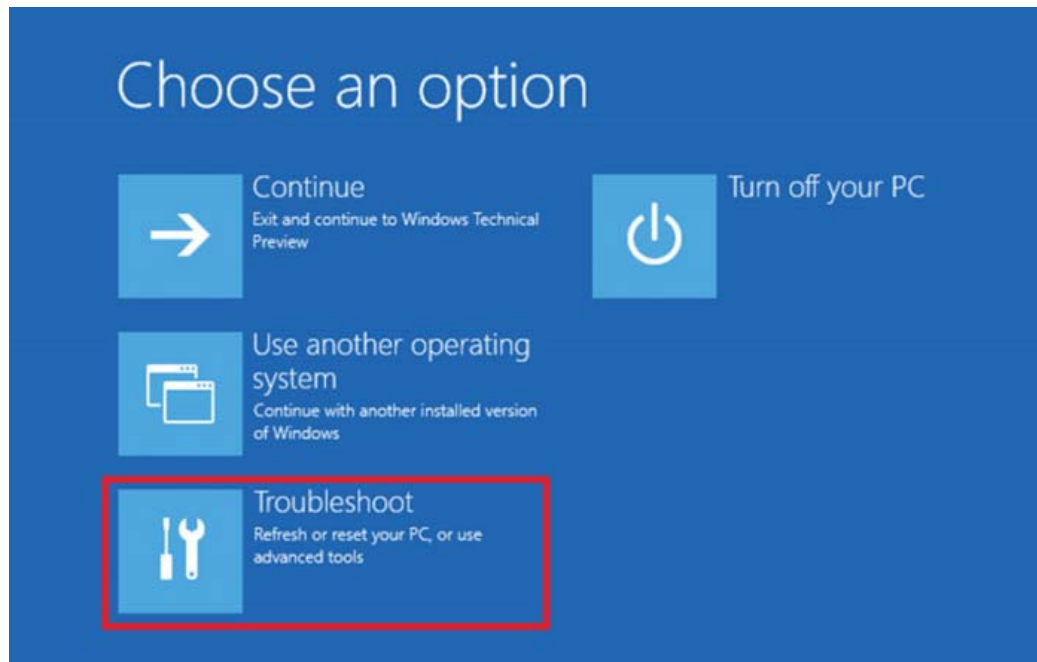

8. The **Troubleshoot** menu will be shown
9. Select '*Advanced Options*' using **TAB** key and then press **ENTER** key

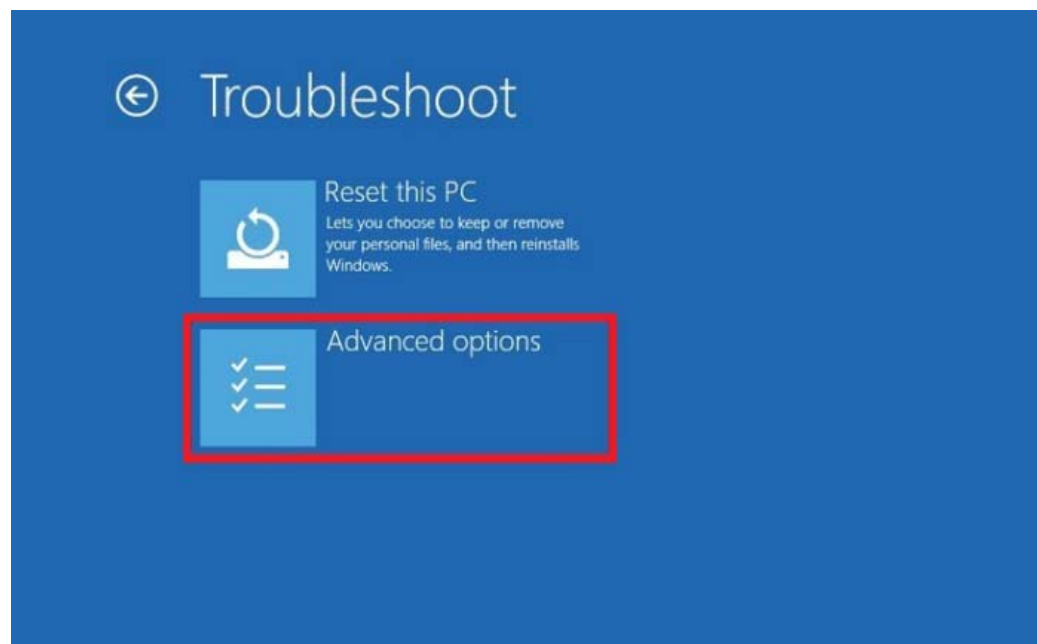

- 10. The **Advanced options** menu will be shown
- 11. Select 'System Image Recovery' using **TAB** key and then press **ENTER** key

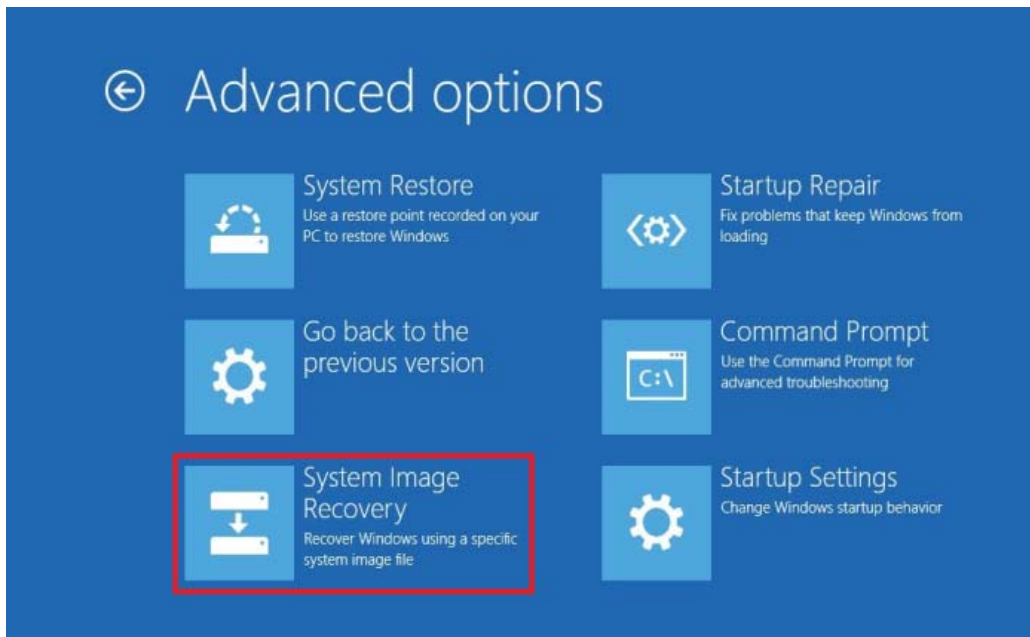

- 12. Enter the password '*dla*' and press **CONTINUE**

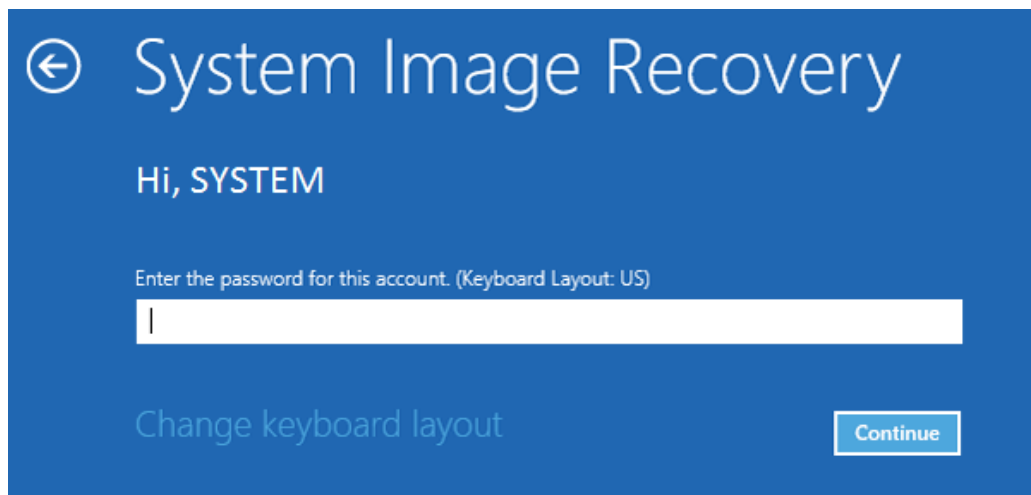

13. Select 'Use the latest available system image (recommended)'

14. Press **NEXT** to continue

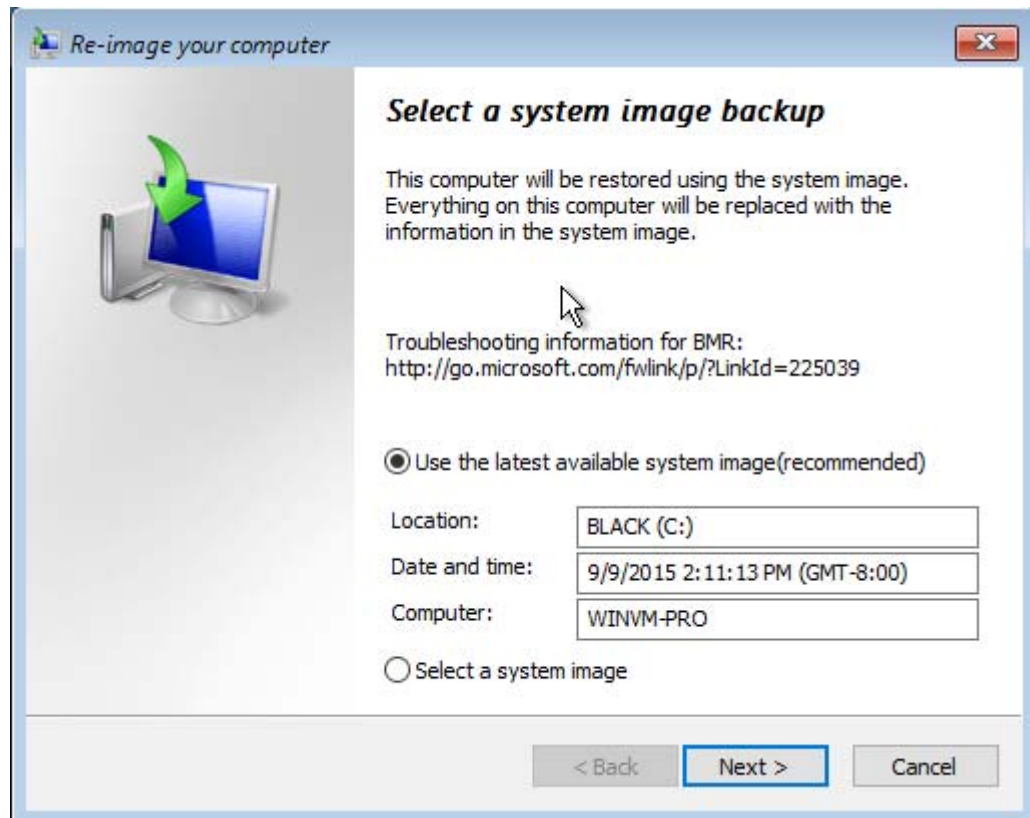

15. Press **NEXT** to continue

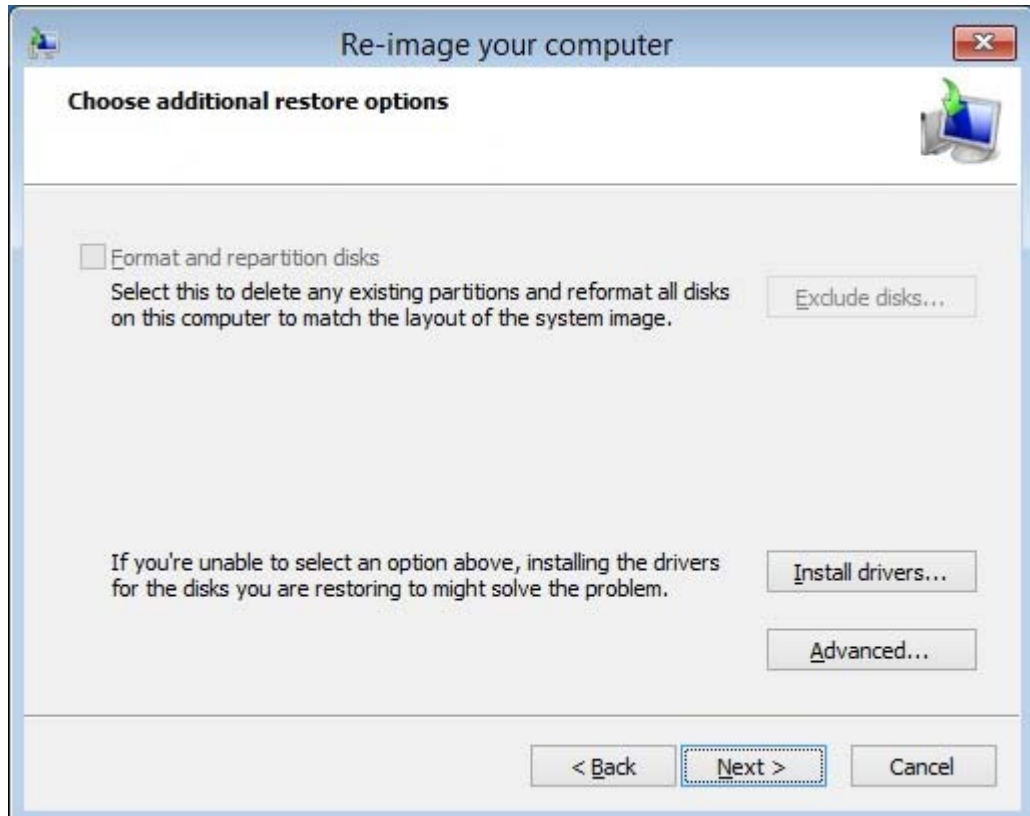

16. Press **FINISH** to continue

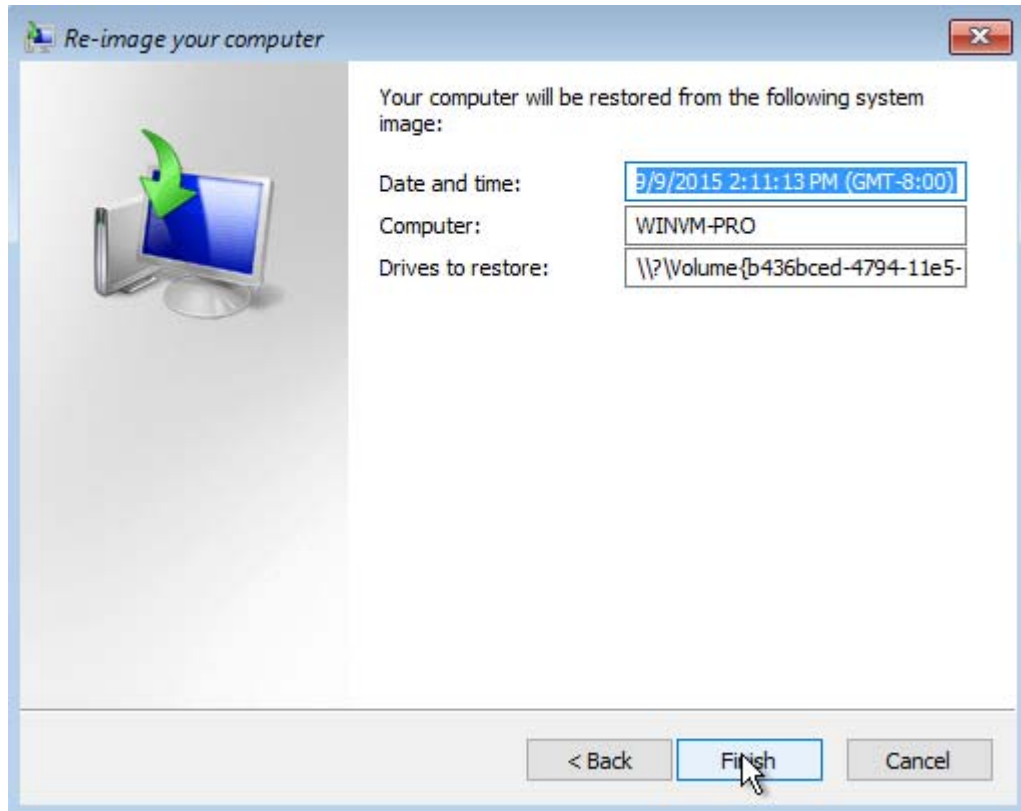

17. Press **YES** to continue

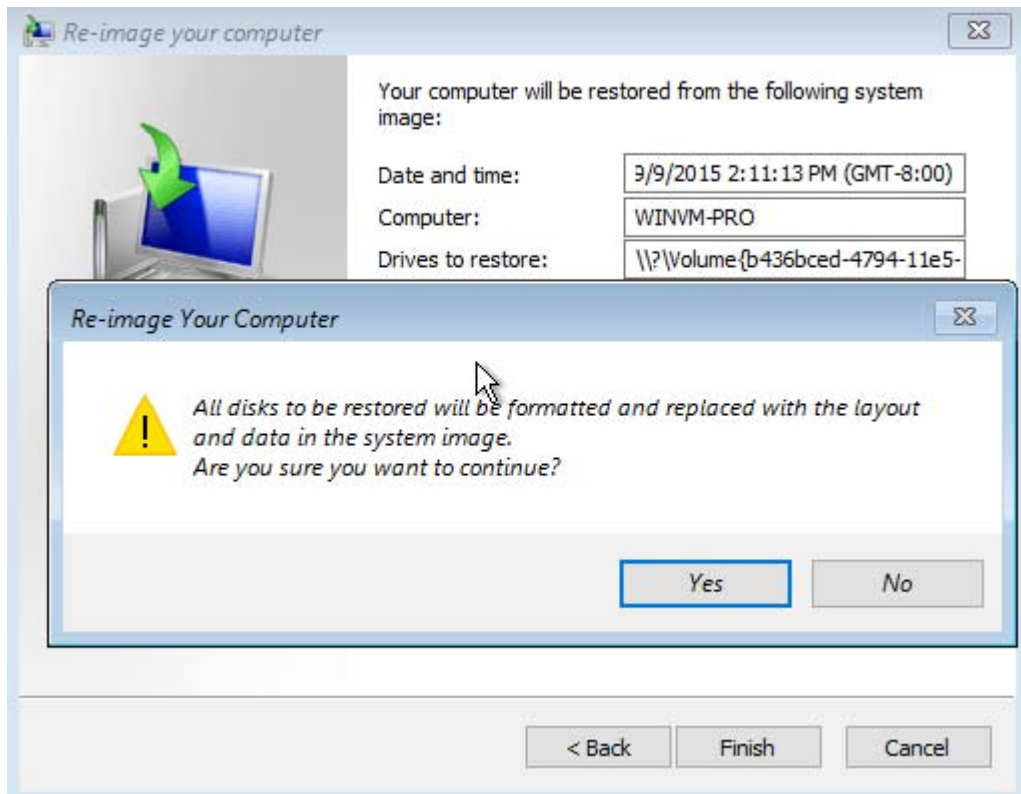

18. **Wait** for disks restoring

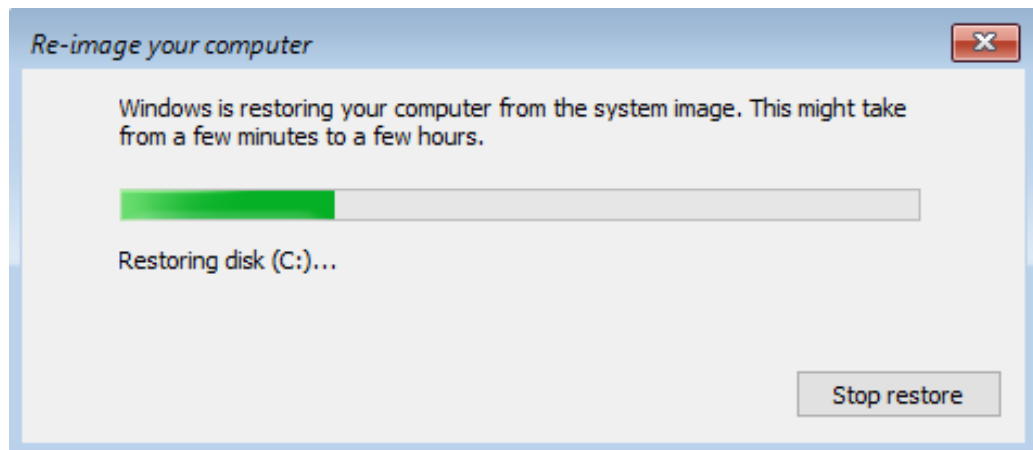

19. The system will **restart** automatically

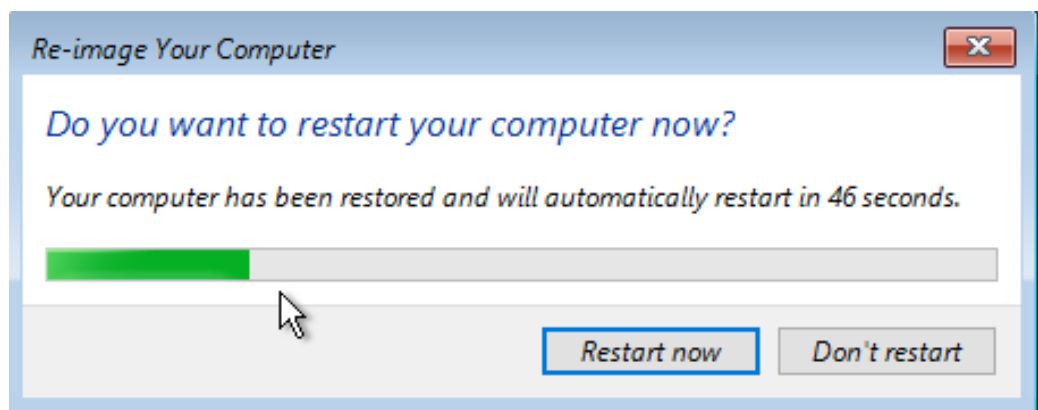

20. **Turn ON** the system

21. The system will perform the **New Hardware Configuration** procedure (approx. 2 minutes)

22. **Wait** for the end of the procedure

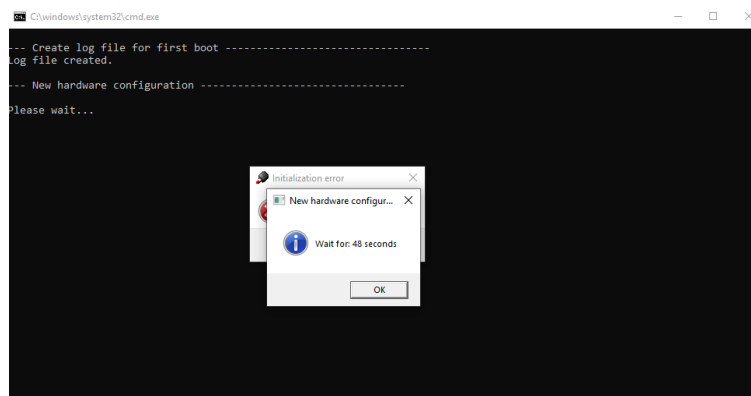

23. The system will **restart** automatically



CAUTION: DO NOT turn OFF or UNPLUG the laser marker while Windows® is restarting!

24. After the restart an error message will advise you that Lighter™ initialization file is not present. Press **OK** to continue:

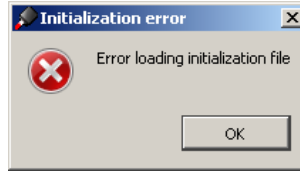

NOTE: In order to work, the marking software must be customized with the factory configuration file. The custom `laser.inz` file is present in the Partner Area of the Datalogic website (see “Preliminary Operation” on page 123).

25. Insert the USB drive with the `laser.inz` file in a USB port of the laser marker.
26. Navigate to the folder ***Fileinz and report*** and copy customized `laser.inz` to ***D:\DATA\CONFIG***

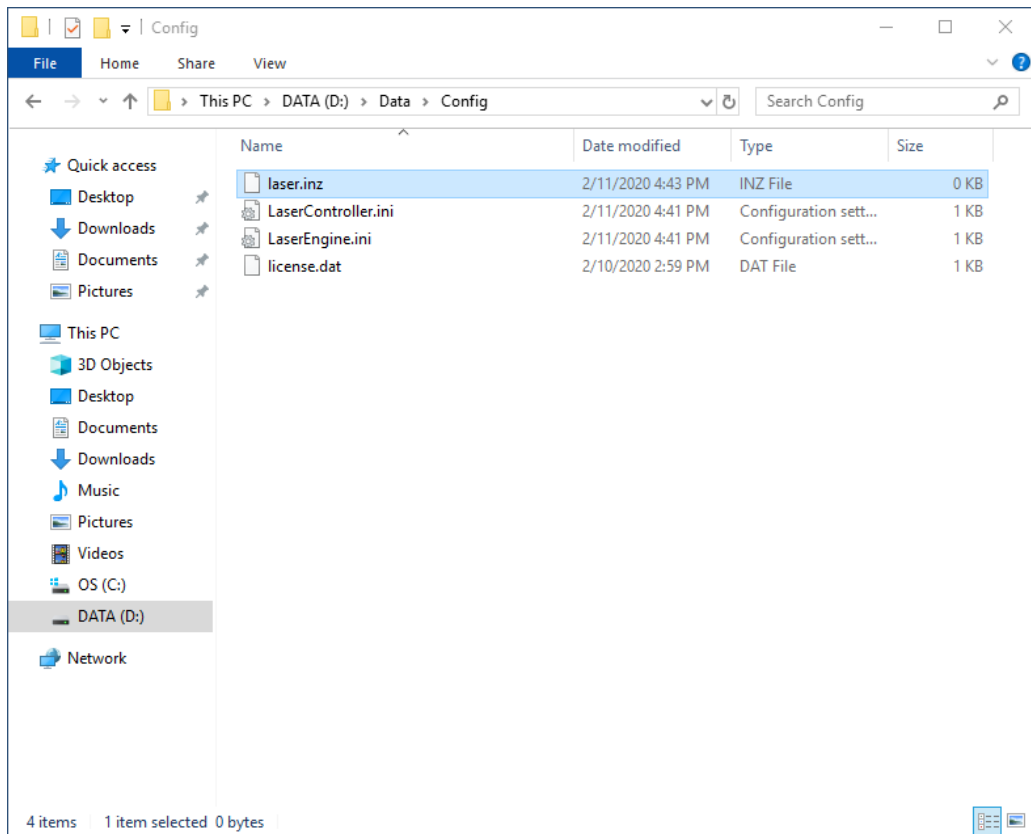

27. Navigate to the folder **Test Layouts**, select the **right test layout** files depending on the laser marker model and copy them to **D:\DATA\DOCS\LAYOUTS**

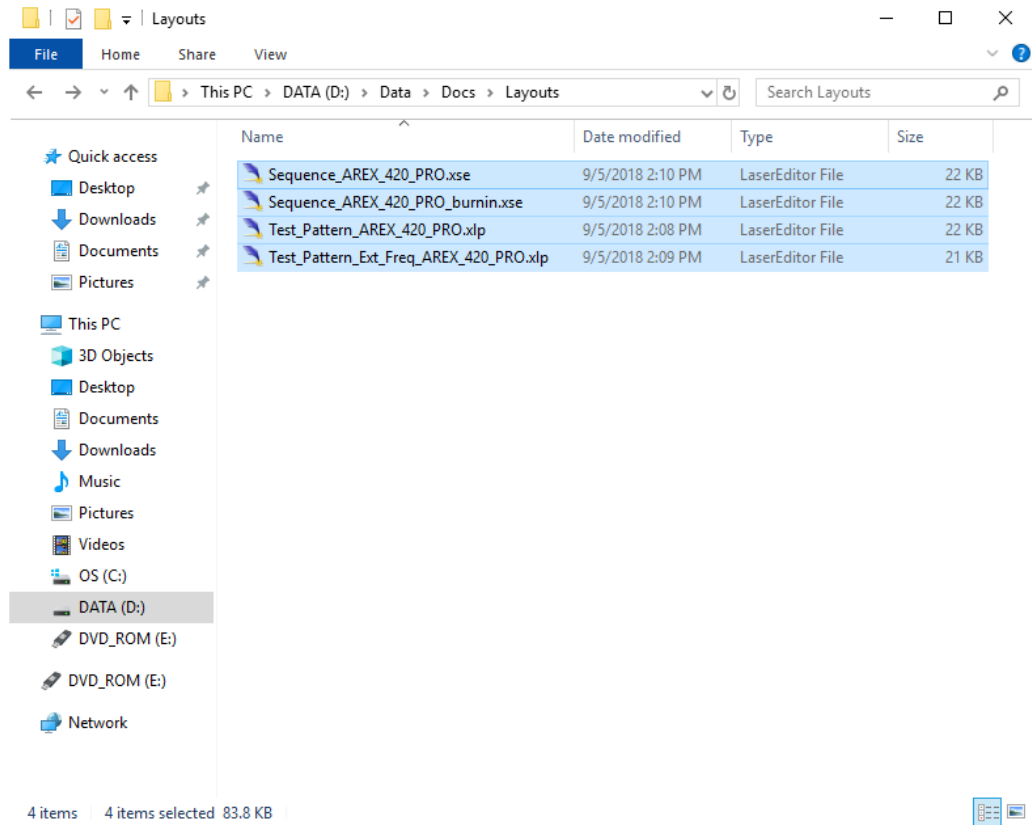

28. **Shut down** the operating system:

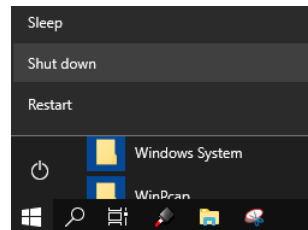

CAUTION: DO NOT turn OFF or UNPLUG the laser marker while Windows® is shutting down!

29. **Wait** until the operating system is shutting down
30. Turn **OFF** the laser marker

APPENDIX G

MECHANICAL DRAWINGS

CONTROL RACK

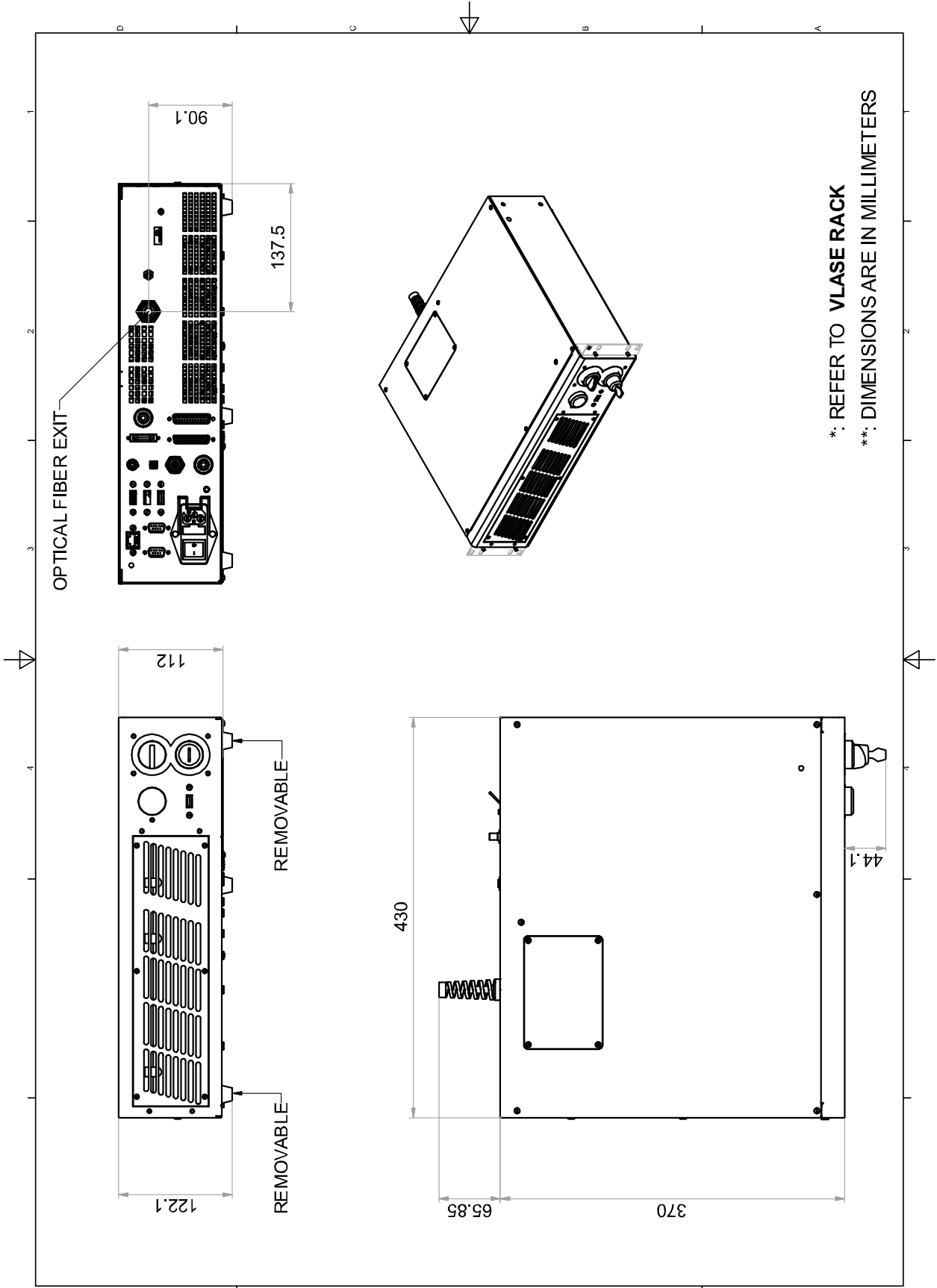

NOTE: Please refer to Datalogic website for detailed drawings.

RESONATOR

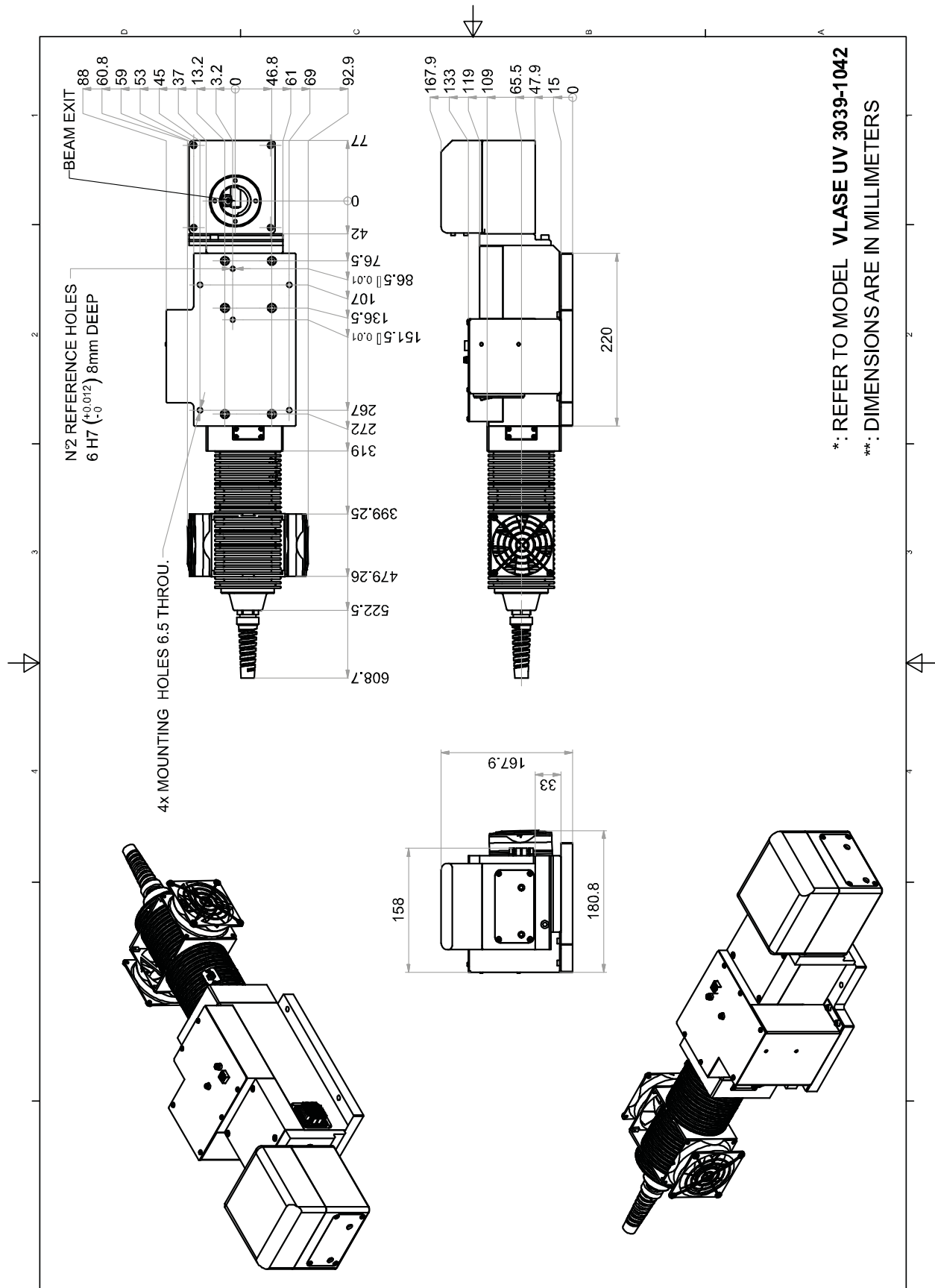

NOTE: Please refer to Datalogic website for detailed drawings.

© 2021-2022 Datalogic S.p.A. and /or its affiliates • All rights reserved • Without limiting the rights under copyright, no part of this documentation may be reproduced, stored in or introduced into a retrieval system, or transmitted in any form or by any means, or for any purpose, without the express written permission of Datalogic S.p.A. and/or its affiliates • Datalogic and the Datalogic logo are registered trademarks of Datalogic S.p.A. in many countries, including the U.S. and the E.U.

 **DATALOGIC**
www.datalogic.com

Datalogic S.r.l.

Via S. Vitalino, 13 | 40012 Calderara di Reno | Bologna - Italy
Tel. +39 051 3147011 | Fax +39 051 3147205

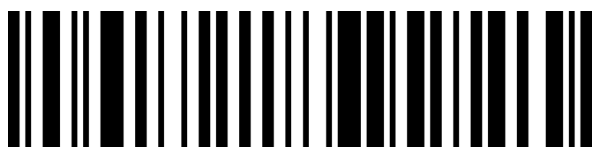

801000090

(Rev A)

December 2022